

MOLD REFRESHER TRAINING PROGRAM

PREPARED FOR & PRESENTED TO
NEW YORK CITY HOUSING AUTHORITY

STUDENT MANUAL

EEA

ENVIRONMENTAL EDUCATION ASSOCIATES

888 4 ENV EDU *environmentaleducation.com*





ENVIRONMENTAL EDUCATION ASSOCIATES
working to make our communities healthy

MOLD REFRESHER TRAINING PROGRAM TABLE OF CONTENTS

Section	Page Number
NYCHA Standard Procedure Manual (SP 040:14:1)	3
Interim Guidance on Wall Breaks	101
Interim Guidance on Pipe Insulation	105
Interim Guidance on Roof Fan Operation and Inspection	111
NYCHA Standard Procedure Manual (SP 040:18:2)	139

PREFACE

This training course manual has been created to provide staff of the New York City Housing Authority (NYCHA) with that organization's standard procedures, guidance and a general managers directive (GM) as prepared by NYCHA for NYCHA staff. The procedures and practices detailed in these pages incorporate current procedures at the time of printing. The reader should be advised that as procedures evolve, so do the methods for identifying and remediating mold contamination. Therefore, we emphasize the need for the reader to obtain the most up to date information available.

Standardized procedures, technical expertise and common sense are major components of a successful project. The reader is encouraged to improve further on the techniques provided in this manual as experience is gained through field practice. This will ensure that the mold industry continues to evolve to improve all facets of remediation and worker protection.

ACKNOWLEDGEMENTS & REFERENCES

It would be impossible to acknowledge all of the individuals who have contributed to the development of this course manual in some fashion or manner. Environmental Education Associates, Inc. is extremely grateful to those who have generously shared their knowledge, expertise and experiences throughout the development process. Special thanks to Alisa Raab, Charlotte McLellan and Marvin Jean-Jacques who contributed to the creation of this manual and associated training courses.

DISCLAIMER

This manual was developed using NYCHA documents. This manual has no official weight or legal merit outside NYCHA. Procedures and practices contained in this manual have not been reviewed or approved by regulatory agencies. It is the responsibility of the user to verify compliance with all applicable federal, state or local regulatory agencies.

Environmental Education Associates, Inc. makes no representation, warranty or guarantee in connection with the materials in this course manual or the oral presentation made in connection with the materials. EEA hereby disclaims any liability or responsibility for loss or damage resulting from their use and for any violation of federal, state or municipal regulation, ordinance or law resulting directly or indirectly from their use.

Mention of any trade names, commercial products, manufacturers or other businesses in the material or by the presenter does not constitute an endorsement by EEA.

NYCHA STANDARD PROCEDURE MANUAL
SP 040:14:1

NYCHA STANDARD PROCEDURE MANUAL

SP 040:14:1, MOLD/MILDEW CONTROL IN NYCHA RESIDENTIAL BUILDINGS

TABLE OF CONTENTS

I. PURPOSE	1
II. POLICY.....	1
III. APPLICABILITY.....	1
IV. INTRODUCTION TO MOLD AND MOISTURE CONTROL	1
V. DEFINITIONS	3
VI. REVIEW CYCLE.....	7
VII. RESPONSIBILITIES.....	7
A. Office of Mold Assessment and Remediation.....	7
B. Operations Departments	9
C. Lead Hazard Control Department.....	18
D. Employees Who Remediate or Correct the Root Causes of Mold.....	18
E. All NYCHA Employees Performing Work in Apartments	19
F. Compliance Department.....	19
G. Environmental Health and Safety Department	19
H. Ombudsperson Call Center.....	20
I. Office of Mold Assessment and Remediation Mold Response Unit.....	21
J. Employees Who Manage Vendors That Perform Mold Remediation.....	21
VIII. PROCEDURE.....	23
A. Creating and Scheduling Mold Service Requests.....	23
B. Inspecting Mold Conditions in Apartments	25
C. Inspecting Mold Conditions in Public Spaces and Other Non-Residential Spaces	38
D. Remediating Mold and Related Conditions – Apartments, Public Spaces, and Other Non-Residential Spaces.....	39
E. Correcting Root Causes	41
F. Time Frames to Respond to Mold and Related Issues.....	42
G. Reasonable Accommodations.....	43
H. Quality Assurance	43
I. Resident Engagement and Communication	50
IX. OUTPUTS, REPORTS, AND RECORDKEEPING.....	51
A. Outputs.....	51
B. Reports.....	51
C. Recordkeeping	52
X. TRAINING REQUIREMENTS.....	52
XI. PERFORMANCE METRICS.....	55
XII. NON-COMPLIANCE	55
XIII. FORMS.....	56
XIV. WORKFLOW	56
XV. REVIEW/REVISION HISTORY PAGE.....	57
XVI. APPENDICES.....	60
A. Appendix A – Remediation Methods	60
B. Appendix B – HA Numbers for Mold Related Tools and Supplies	65
C. Appendix C – Sample Photos of Mold Conditions	71
D. Appendix D – Instructions for the New Version of the Testo App	72

Table of Contents
Page i
Index No. 040:14:1
Revised 6/11/2024

NYCHA STANDARD PROCEDURE MANUAL

E. Appendix E – Instructions for Using a Moisture Meter.....	78
F. Appendix F – Creating a Mold Inspection in Apartments on the Handheld.....	79
G. Appendix G – Creating a Mold Inspection in Public Spaces and Other Non-Residential Spaces on the Handheld.....	83
H. Appendix H – Scorecard Factors.....	84

NYCHA STANDARD PROCEDURE MANUAL

NEW YORK CITY HOUSING AUTHORITY

STANDARD PROCEDURE

SUBJECT	PROCEDURE OWNER	APPROVED DATE	APPROVED BY	INDEX NO.
MOLD/MILDEW CONTROL IN NYCHA RESIDENTIAL BUILDINGS	HEALTHY HOMES	Draft Effective May 21, 2014 Reissued June 3, 2015 Revised December 19, 2018 Revised February 26, 2020 Date: <u>6/11/24</u>	 Eva Trimble Chief Operating Officer	040:14:1

I. PURPOSE

This Standard Procedure establishes responsive measures to mold and its root causes in New York City Housing Authority (NYCHA) public housing locations and creates protocols to protect the health of residents and staff when remediating mold and identifying and correcting its root causes.

II. POLICY

It is the policy of NYCHA to establish a cooperative partnership between staff and residents to quickly identify mold and its root causes. NYCHA will promptly remove mold from NYCHA locations and correct the root cause of the mold growth (for example, the moisture source and/or inadequate ventilation).

III. APPLICABILITY

This Standard Procedure applies to staff responsible for the operation and maintenance of NYCHA public housing developments that receive Section 9 subsidies from the U.S. Department of Housing and Urban Development (HUD). This procedure does not apply to Permanent Affordability Commitment Together (PACT) developments.

IV. INTRODUCTION TO MOLD AND MOISTURE CONTROL

Moisture control is the key to mold control. Mold will often grow in moist or wet indoor areas. Common sites for indoor mold growth include bathroom and kitchen walls and ceilings, cabinet bases and walls beneath sinks, interior surfaces of walls, ceilings below leaks from above or directly below roofs, and areas around windows where moisture condenses. Common sources or causes of water or moisture problems include condensation of shower vapors on bathroom walls and ceilings, condensation in wall cavities from inadequately insulated cold water pipes, leaks from plumbing pipes, roof and façade leaks, and drain backups/overflows.

The general approach to preventing mold growth in buildings is to keep exterior moisture out of the building, and to control moisture from internal sources. To this end, it is important to establish a cooperative partnership among NYCHA staff and residents so that conditions that require attention are identified and dealt with promptly.

Exposures from residential excessive moisture and mold have been associated with increased risks for respiratory symptoms, asthma, hypersensitivity pneumonitis, rhinosinusitis, bronchitis,

NYCHA STANDARD PROCEDURE MANUAL

and respiratory infections. NYCHA staff must take action to detect and correct leaks, condensation problems, and floods as soon as they are discovered. The potential for building structural damage, mold growth, and increased adverse health effects can and must be reduced by limiting the buildup of indoor moisture.

Top Ten Things NYCHA Staff Should Know About Mold and Moisture

1. Potential health effects and symptoms associated with exposure to mold and excessive moisture include allergic reactions, asthma, and other respiratory complaints.
2. Mold can be found almost anywhere; it can grow on virtually any substance if moisture is present. For example, there are molds that can grow on sheetrock, painted plaster and concrete, wood, paper, carpet, foods, and even dusty inorganic building materials.
3. There is no practical way to eliminate all mold and mold spores in an indoor environment; the way to control indoor mold growth is to control moisture.
4. If mold is a problem in an apartment or building, we must clean up the mold and eliminate the sources of moisture.
5. Fix the source of the water problem or leak to prevent mold growth, including repairing leaky roofs and façades and restoring adequate exhaust ventilation in bathrooms and kitchens.
6. Reduce indoor humidity (to 30-60%) to decrease potential for mold growth by: venting bathrooms and kitchens, using air conditioners and de-humidifiers, and increasing ventilation. Staff shall ensure that mechanical ventilation is functioning (clear lateral ductwork and operable roof fans). Further, staff can use a hygrometer to check the relative humidity in a resident's apartment.
7. Clean and dry any damp or wet building materials within 24-48 hours to prevent mold growth. Advise residents to clean and dry any damp furnishings and other personal property within 24-48 hours.
8. Clean minor levels of mold off hard surfaces with water and detergent, and dry completely. Absorbent materials, such as sheetrock, that are moldy may need to be replaced.
9. Prevent condensation: reduce the potential for condensation on cold surfaces by assuring that cold water pipes in wall cavities are insulated properly.
10. If needed as a result of asthma, individuals with mold and/or excessive moisture in their apartments are entitled to reasonable accommodations from NYCHA.

NYCHA STANDARD PROCEDURE MANUAL

V. DEFINITIONS

A. Anemometer

An instrument used to measure the air flow or speed of air.

B. Baez Consent Decree

The *Baez et. al. v. NYCHA Modified Amended Stipulation and Order of Settlement* (United States District Court, Southern District of New York, No. 13-cv-08916), which established many of NYCHA's current procedures and protocols for the remediation of mold and excessive moisture, set forth time parameters for NYCHA to complete remediation and repair work, and created a reporting and oversight framework.

C. Borescope

An instrument with a camera used to inspect for leaks or moisture behind a wall through an opening in the wall. It can also be used to observe conditions in other hard to reach places, such as inside an exhaust vent.

D. Child Work Order

A work request created by an authorizing supervisor or worker, or automatically created in Maximo, whenever additional work is needed for a parent work order. Multiple child work orders can be created from a single parent work order.

E. Complex Repairs

Repairs that need skilled trades or other specialized staff to address and may require multiple visits.

F. Craft

The type of worker (e.g. maintenance worker, painter) assigned to remediate mold and moisture or make other related repairs.

G. Cubic Feet Per Minute (CFM)

CFM is the unit of measure for air flow measurements.

H. HEPA Vacuum

A vacuum that uses a high efficiency particulate air (HEPA) filter that is at least 99.97% efficient in removing microscopic particles (monodisperse air particles of 0.3 micrometers in diameter).

NYCHA STANDARD PROCEDURE MANUAL

I. Hygrometer

An instrument used for measuring the moisture content (humidity levels) in the air in an inside space.

J. Independent Data Analyst (IDA)

A court-appointed advisory firm, selected by the Special Master pursuant to the Baez Consent Decree, qualified in forensic data analysis. The IDA is given access to mold and excessive moisture work order data from Maximo, designs the Period Report that measures NYCHA's compliance with the Baez Consent Decree, and reviews and confirms the accuracy of the Period Reports. The IDA partners with NYCHA to validate mold and leak reporting tools and performs related analyses.

K. Independent Mold Analyst (IMA)

A court-appointed individual or advisory firm selected by the Special Master pursuant to the Baez Consent Decree, who is licensed as a mold assessor by the New York State Department of Labor, and is certified as an industrial hygienist by the American Industrial Hygiene Association. The IMA provides assistance with mold assessment and remediation to the Office of Mold Assessment and Remediation upon request, performs quality assurance inspections of randomly selected apartments on a quarterly basis, makes recommendations for improved compliance with this Standard Procedure, and during quality assurance inspections, provides supplemental field training to development employees on performing Mold Busters inspections.

L. Informer Work Management (iWM) App

A work order application used on staff's handheld devices.

M. Initial Mold Inspection

The process by which NYCHA diagnoses and documents a mold or excessive moisture condition and identifies the root cause(s).

N. Inspector

A property maintenance supervisor, assistant property maintenance supervisor, property manager, or maintenance worker who is trained and authorized to perform initial mold inspections and quality assurance mold inspections using the iWM app. Inspectors are required to complete the Mold Inspection and Mold Building Science Trainings before they can perform mold inspections.

O. Large Remediation Job

The remediation of 100 or more square feet of mold in a room. Large remediation jobs are performed by lead abatement workers or a certified contractor.

NYCHA STANDARD PROCEDURE MANUAL

P. Mildew

A term that is used to refer to some kinds of mold. On the iWM app, the term 'mildew' is used to describe both mildew and mold.

Q. Moisture Meter

An instrument used to measure the subsurface moisture content of a given structure (such as walls, ceilings, floors, and components such as kitchen and bathroom cabinets).

R. Mold

A fungus that grows on, and sometimes in, damp surfaces and objects. Live spores act like seeds, forming new mold growth (colonies) when they find the right conditions. Mold is most likely to grow where there is water or excessive moisture such as in bathrooms. Mold at NYCHA is measured by the square footage identified in each room.

S. Mold and Leak Performance Scorecard ("Scorecard")

An assessment tool that evaluates NYCHA's performance related to mold and leak remediation based on selected key performance metrics and provides the Operations Department with actionable data. It was developed in collaboration with the independent data analyst (IDA). See Appendix H – Scorecard Factors.

T. Mold Resistant Paint

Paint that contains a chemical fungicide that discourages the growth of mold on surfaces. There must be no mold present when the paint is applied.

U. Mold Resistant Sheetrock

Paperless sheetrock with a fiberglass face that is designed to discourage the growth of mold.

V. Mold Service Level Agreement

Simple repairs are completed within seven calendar days. Complex repairs are completed within 15 calendar days.

W. Ombudsperson

An independent individual appointed by the Special Master pursuant to the Baez Consent Decree who has the authority to investigate mold and excessive moisture complaints and to order appropriate relief. Residents may contact the ombudsperson with any concern about mold or excessive moisture repairs through the Ombudsperson Call Center which is operated by the independent data analyst (IDA).

NYCHA STANDARD PROCEDURE MANUAL

X. Parent Work Order

An original mold work request initiated by a resident, created by NYCHA staff, or automatically created in Maximo.

Y. Public Space

Part of a residential property available for use by occupants of more than one apartment, including, but not limited to, hallways, stairways, laundry rooms, recreational rooms, playgrounds, community centers, on-site day care facilities, garages, and boundary fences.

Z. Quality Assurance Mold Inspection

An inspection in which a NYCHA inspector verifies that no mold, moisture, or water damage remains at the location of the initial complaint, and that all remediation and repair work was completed.

AA. Recurrence

The reappearance of mold in areas that previously had remediation performed.

BB. Root Cause

The fundamental reason for the occurrence of mold, water damage, or moisture. The root cause could be the source of water or excessive moisture (such as leaking pipes or fixtures, condensation) or the lack of ventilation (such as blocked exhaust ducts, closed windows). Identifying and correcting the root cause in response to a mold complaint is essential to ensuring that the mold or moisture condition related to that root cause does not recur.

CC. Simple Repairs

Repairs that can be completed by property management staff.

DD. Special Master

A court-appointed individual tasked with overseeing NYCHA's compliance with the Baez Consent Decree and subsequent Agreements and Orders, and with making recommendations to the Court concerning steps that should be taken to bring NYCHA into compliance.

EE. Unfounded

A term used to characterize certain mold work orders for which staff performed an initial mold inspection but did not identify mold, moisture, or water damage during the inspection. Inspectors must submit moisture meter measurements and photographs to document a work order with an unfounded condition.

NYCHA STANDARD PROCEDURE MANUAL

FF.Vendor

A third-party under contract with NYCHA. If a vendor performs any work described in this Standard Procedure, they must follow all applicable laws, regulations, and guidance, and NYCHA's policies, procedures, and guidelines regarding mold, including this Standard Procedure and their contract.

GG. Wet Measurement

A moisture meter measurement of a surface structure that is equal to or greater than 599 (on a scale of 0 to 999).

VI. REVIEW CYCLE

The Healthy Homes Department shall review this Standard Procedure at least once every three years; and advise the Compliance Department via e-mail if no changes are needed or submit its revisions to the procedure by submitting NYCHA Form 022.008, *Procedure Development Request*.

VII. RESPONSIBILITIES

A. Office of Mold Assessment and Remediation

The Office of Mold Assessment and Remediation:

1. Sets a NYCHA-wide strategy to improve mold and leak compliance measures.
2. Monitors key development-level mold-related indicators including, but not limited to, parent and child mold work order completion timeframes, mold recurrence rates, and unfounded inspection rates.
3. Performs mold inspections on select work orders at developments when complaints about high rates of mold recurrence, unfounded inspections and report findings, or mold complaints of 100+ square feet are referred by:
 - a. The office of the chief executive officer
 - b. The office of the chief operating officer
 - c. The Compliance Department
 - d. The Environmental Health and Safety Department
 - e. The Federal Monitor
 - f. The Ombudsperson Call Center

NYCHA STANDARD PROCEDURE MANUAL

4. Monitors the efficiency of mold work order scheduling and provides follow up recommendations to neighborhood administrators or Skilled Trades deputy directors, as applicable.
5. Prepares quarterly reports about the Office of Mold Assessment and Remediation's mold remediation efforts within NYCHA developments.
6. Provides technical expertise to Property Management staff, the Compliance Department, and the Environmental Health and Safety Department.
7. Tracks and reports NYCHA's obligations under the Baez Consent Decree and related supplemental agreements, and deliverables based on the settlement agreement between NYCHA, HUD, the U.S. Attorney's Office for the Southern District of New York, and New York City entered into on January 31, 2019.
8. Ensures the Mold Response Unit responds to complaints received by the Ombudsperson Call Center.
9. Manages large complex jobs related to mold and leaks including updating building lines.
10. Serves as NYCHA's liaison to the Special Master, Baez Consent Decree plaintiffs, and court-appointed entities.
11. Ensure employees follow all training outlined below in Section X., Training Requirements.
12. Administer the scorecard, including providing access, training, and oversight.
13. Use the Enhanced Oversight Program to create joint strategies to improve mold and leak compliance, address specific backlog issues, and assist with procurement. This includes:
 - a. Assisting staff at select developments with complex mold inspections.
 - b. Providing qualified inspection teams for select developments that need assistance.
 - c. Providing a qualified mold cleaning team for select developments that need assistance (up to 99 square feet).
 - d. Applying mold resistant paint at select developments.
14. Oversee all NYCHA mold initiatives.
15. Office of Mold Assessment and Remediation construction project managers manage vendors procured by the Office of Mold Assessment and Remediation who perform tasks related to mold.

NYCHA STANDARD PROCEDURE MANUAL

B. Operations Departments

1. Vice presidents for property management:

- a. Monitor key borough, neighborhood, and consolidation-level data for mold, including but not limited to:
 - (1) Response rates to reported mold conditions (for example, rate of completion of mold inspections, median dates to inspect for reported mold conditions, percentage of compliance within 45 calendar days of quality assurance mold inspections);
 - (2) Simple and complex repair completion timeframes;
 - (3) Recurrence rates for mold;
 - (4) Proportion of mold work orders that are closed as unfounded.
- b. Monitor the scorecard for performance of the borough, neighborhoods, and consolidations.

2. Operations administrators:

- a. Monitor key borough, neighborhood, and consolidation-level data for mold, including but not limited to:
 - (1) Response rates to reported mold conditions (for example, rate of completion of mold inspections, median dates to inspect for reported mold conditions, percentage of compliance within 45 calendar days of quality assurance mold inspections);
 - (2) Simple and complex repair completion timeframes;
 - (3) Recurrence rates for mold;
 - (4) Ratio of scheduled and missed appointment.
- b. Provide recommendations, when needed, regarding the items listed directly above in a.(1)-a.(4).
- c. Monitor the scorecard for performance of the borough, neighborhoods, and consolidations.

3. Skilled Trades deputy directors:

- a. Monitor Skilled Trades administrators, borough planners, and Skilled Trades employees to hold them accountable for responding to scheduled remediation and

NYCHA STANDARD PROCEDURE MANUAL

repair child mold work orders, ensuring they are addressed following required timeframes and protocols established for identifying and correcting root causes.

- b. Provide recommendations, when needed, regarding mold repairs, whether the repair is performed by NYCHA staff or an authorized vendor.
 - c. Work closely with Skilled Trades administrators and supervisors to ensure that Skilled Trades employees:
 - (1) Visit appointments as scheduled.
 - (2) Perform work following the protocols and guidance outlined in this Standard Procedure.
 - d. Review Skilled Trades neighborhood staffing schedules and make final adjustments.
 - e. Ensure that Skilled Trades staff complete all compliance-related trainings.
 - f. Monitor purchase orders and escalate to neighborhood administrators and Skilled Trades supervisors when orders are not approved in a timely manner.
 - g. Ensure materials are checked weekly and follow up if necessary to ensure they are available for performing work orders.
 - h. Monitor the scorecard for Skilled Trades work order trends in the borough, neighborhoods, and consolidations.
4. Skilled Trades administrators:
- a. Provide direction and guidance on mold to borough and neighborhood planners.
 - b. Make decisions regarding scheduling and deployment of floating Skilled Trades staff for mold work orders.
 - c. Provide a list of active Skilled Trades staff (including names and titles) and Skilled Trades vacation schedules to neighborhood planners, borough planners, and property managers to plan for mold work orders.
 - d. Review and approve final Skilled Trades vacation schedules to plan for mold work orders.
 - e. Troubleshoot any planning issues and/or productivity performance of Skilled Trades staff for mold work orders with neighborhood planners and correct them.
 - f. Monitor scheduling of Skilled Trades staff to ensure that complex repairs that do not require capital improvements are scheduled and completed within 15 calendar days after a leak or excessive moisture condition is detected or reported to NYCHA. If

NYCHA STANDARD PROCEDURE MANUAL

NYCHA is unable to comply with this timeframe, use best efforts to prioritize the scheduling and completion of these work orders.

- g. Troubleshoot and correct gaps in scheduling and planning for mold work orders.
 - h. Monitor the scorecard for Skilled Trades work order trends in the borough, neighborhoods, and consolidations.
5. Skilled Trades borough planners:
- a. Schedule Skilled Trades staff to ensure that complex repairs performed by glaziers, roofers, or reserve teams that do not require capital improvements are completed no later than 15 calendar days after a leak or excessive moisture condition is detected or reported to NYCHA. If NYCHA is unable to comply with this timeframe, use best efforts to prioritize the scheduling and completion of these work orders.
 - b. Schedule initial mold inspections.
 - c. Schedule newly created glaziers and roofers mold work orders.
 - (1) Review all open work orders for an apartment to determine the proper sequencing of Skilled Trades staff.
 - (2) Schedule all work orders sequentially to keep the dates in close date range to each other to ensure timely completion of repair, in coordination with the neighborhood planner.
 - (3) Coordinate appointment times with residents and Skilled Trades supervisors.
 - (4) Advise on the use of vendors for a bundle of work orders, if necessary and cost effective.
 - d. Verify Skilled Trades staff attendance and scheduled assignments for mold work orders with Skilled Trades supervisors.
 - e. Reschedule appointments for mold work orders with residents and Skilled Trades supervisors, when needed.
 - f. Partner with Skilled Trades administrators to schedule and deploy floating Skilled Trades staff for mold work orders.
 - g. Review development the mold work orders list to identify what materials are needed.
 - h. Check materials list received from the Skilled Trades supervisor regularly to ensure that materials for mold work orders are in stock before scheduling work.

NYCHA STANDARD PROCEDURE MANUAL

- i. Input vacation schedules in Maximo for each borough-level Skilled Trades staff and reserve teams after receiving the schedules from the Skilled Trades administrator and Skilled Trades deputy director to plan for mold work orders.
 - j. Monitor the scorecard for Skilled Trades work order trends of the borough, neighborhood, and consolidation.
6. Neighborhood administrators:
- a. Monitor Property Management operations and hold neighborhood planners, property managers, and property maintenance supervisors, accountable for responding to mold work orders.
 - b. Monitor the scorecard for performance of the neighborhood and consolidations and set plans to address performance issues of the neighborhood and/or consolidations.
 - c. Set priorities and plans for addressing mold work orders on the neighborhood level.
 - (1) Review the weekly schedule of Skilled Trades appointments for underbooking or overbooking to plan for mold work orders.
 - (2) Include mold inspections on daily check-ins with Property Management supervisors and follow up on child work orders generated by the mold inspections with the neighborhood planner at least once per week.
 - (3) Ensure that work orders get scheduled and rescheduled as needed and that conditions are addressed in compliance with required timeframes and protocols established for identifying and correcting root causes.
 - (4) Review the work order backlog and determine what work could be performed by vendors.
 - d. Monitor development budgets and requests for materials for mold work orders needed for Skilled Trades staff and:
 - (1) Ensure that each account has adequate funding for anticipated usage.
 - (2) Prepare budget modifications and revisions, as needed.
 - (3) Approve requisitions for materials in Oracle submitted by Skilled Trades supervisors.
 - (4) Designate a backup for the neighborhood planner and ensure that calls to the neighborhood planner's phone number are forwarded to the designated backup (another neighborhood planner, borough planner, or neighborhood secretary).

NYCHA STANDARD PROCEDURE MANUAL

- e. Monitor the scorecard for performance of the neighborhood and consolidations once per week.
 - f. Oversee vendor skilled trade work orders to ensure they are closed.
7. Neighborhood planners:
- a. Schedule neighborhood-level Skilled Trades work orders after a mold or excessive moisture condition is detected and reported to NYCHA to ensure that complex repairs performed by any trade other than glaziers and roofers are completed within 15 calendar days, and inform Property Management of any non-Skilled Trades repair work which needs to be coordinated to complete the job. If NYCHA is unable to comply with this timeframe, use best efforts to prioritize the scheduling and completion of these work orders.
 - b. Monitor the scorecard and set plans to address performance issues of the neighborhood and/or consolidations once per week.
 - c. Answer resident calls regarding mold-related child work orders:
 - (1) Review all open work orders for the unit to determine proper sequencing of Skilled Trades work and staff.
 - (2) Schedule all Skilled Trades work related to the call and all open Skilled Trades work orders in the apartment sequentially to make all work order dates in close date range to each other to ensure timely completion of the repair.
 - (3) Check all open work orders for duplication and consolidate them when necessary.
 - (4) Coordinate appointment times with residents and Skilled Trades supervisors.
 - (5) Advise the neighborhood administrator on the use of vendors for a bundle of work orders, if necessary and cost effective.
 - d. Schedule backlog mold work orders when the resident has not called.
 - (1) Work orders pending scheduling, including but not limited to, the work orders in status Approved (APPR), Waiting to Schedule (WTSCH), and Failed to Schedule (FAILSCH).
 - (2) Work orders with a scheduled (SCHED) date in the past.
 - (3) Ensure all Skilled Trades work orders for the entire apartment are listed. All child work orders from a parent mold inspection work order have the subwork type of 'MOLD.'

NYCHA STANDARD PROCEDURE MANUAL

- (4) Schedule all Skilled Trades work orders for the unit in the correct sequence.
 - (5) Perform two attempts to contact the resident to obtain a scheduled date. Document in the work order notes all attempts made to contact the resident. The neighborhood planner proceeds with scheduling a work order if the resident cannot be reached.
 - (6) E-mail NYCHA Form 088.168, *Notice of Scheduled Appointment for Repairs*, to Property Management to place at resident's apartment door.
 - (7) Upload a copy of NYCHA Form 088.168, *Notice of Scheduled Appointment for Repairs*, to the work order.
- e. Coordinate with the borough planner the scheduling of borough-level Skilled Trades staff to plan for mold work orders.
 - f. Send out the next day's schedule for all Skilled Trades staff to each property management supervisor by close of business to plan for mold work orders.
 - g. Verify Skilled Trades staff attendance and assignments of the day's schedules with Skilled Trades supervisors to plan for mold work orders.
 - h. Reschedule mold appointments with residents and Skilled Trades supervisors when needed.
 - i. Review the development work order list to identify what materials for mold work orders are needed.
 - j. Ensure that materials are in stock before scheduling mold work.
 - k. Forward their phone number to a designated planning back-up when absent (another neighborhood planner, neighborhood secretary, borough planner) to plan for mold work orders.
 - l. Work with the neighborhood secretary to input vacation schedules in Maximo for the neighborhood-level Skilled Trades staff after receiving schedules from the Skilled Trades administrator and deputy director to plan for mold work orders.
 - m. Escalate any mold issues to the neighborhood administrator when needed.
 - n. Monitor the scorecard for performance of the neighborhood and consolidation.

NYCHA STANDARD PROCEDURE MANUAL

8. Property managers:
 - a. Monitor key development-level mold indicators in Maximo, including but not limited to, scheduled appointments, parent and child mold work order completion timeframes, mold recurrence rates, and unfounded inspection rates.
 - b. Monitor the customer service delivery aspects of this Standard Procedure to ensure NYCHA's commitments to residents are addressed.
 - c. Ensure that designated staff in Property Management offices respond to requests for reasonable accommodations (including a temporary relocation or permanent transfer to another apartment when appropriate); and review and act on requests in accordance with NYCHA Standard Procedure 040:12:1, *Reasonable Accommodation in Housing for Applicants, Public Housing Residents, and Section 8 Voucher Holders*.
 - d. Ensure that the work orders for simple repairs are scheduled and completed within seven calendar days if the root cause is identified correctly.
 - e. Monitor completion of complex repairs and follow up with the Skilled Trades administrator if work is not completed within 15 calendar days.
 - f. Ensure that quality assurance mold inspections are scheduled and completed between 30-45 calendar days after the last child work order is closed.
 - g. Perform mold inspections when the property maintenance supervisor, assistant property maintenance supervisor, or maintenance workers certified in mold inspection are not available.
 - h. Monitor the scorecard for performance of the consolidation once per week.
9. Property maintenance supervisors and assistant property maintenance supervisors:
 - a. Visit apartments for all mold work order appointments, as scheduled, and perform initial mold inspections, quality assurance mold inspections, and mold re-inspections using the required mold-related tools and equipment. See Appendix B – HA Numbers for Mold Related Tools and Supplies, for a list of tools and equipment.
 - b. Work closely with property managers to ensure that Property Management maintenance staff:
 - (1) Accompany the property maintenance supervisor or property maintenance supervisor during initial mold inspections and quality assurance mold inspections, as required, to correct deficiencies on the spot, if possible.
 - (2) Visit apartments for all mold work order appointments as scheduled.

NYCHA STANDARD PROCEDURE MANUAL

- c. Contact residents using the iWM app.

NOTE: iWM automatically records resident outreach attempts in Maximo.

- d. Schedule child work orders for simple repairs and ensure that development staff visit apartments at the scheduled time and the work orders are completed within seven calendar days if the root cause is identified correctly.
- e. Monitor scheduling and completion of complex repairs, closely communicate with neighborhood planners and borough planners regarding scheduling and prioritizing work orders, and follow up with the Skilled Trades administrator if work is not completed within 15 calendar days
- f. Ensure that residents are notified if Property Management staff might be late or miss a scheduled appointment.
- g. Ensure the timely rescheduling of all mold work orders including initial mold inspections, quality assurance mold inspections, and mold re-inspections.
- h. Make best efforts to assign a different employee to perform the remediation and/or quality assurance mold inspection than the one who performed the initial mold inspection.
- i. Work closely with supervisors of caretaker Xs to ensure that staff is assigned to visit apartments for mold cleaning (less than or equal to 20 square feet of mold in units that are not presumed positive for lead with lead-based paint).
- j. Ensure that quality assurance mold inspections are scheduled and completed between 30-45 calendar days after the last child work order is closed.
- k. Monitor the scorecard for performance of the consolidation.
- l. Assign caretaker Xs who completed the required training to remove less than or equal to 20 square feet of mold (assistant property maintenance supervisors perform this task).
- m. Ensure that assigned caretaker Xs (assistant property maintenance supervisors perform this task):
 - (1) Visit apartments for all mold removal work orders as scheduled and perform the work.
 - (2) Use NYCHA-approved cleaning supplies, tools, and personal protective equipment (PPE).

NYCHA STANDARD PROCEDURE MANUAL

10. Maintenance workers:

- a. Visit apartments for all mold work appointments as scheduled for both repair and mold inspection work orders.
- b. Record resident outreach attempts in the iWM app and Maximo desktop.

11. Skilled Trades supervisors:

- a. Oversee the daily work activities of all Skilled Trades staff to ensure that repairs are completed in required timeframes and following protocols established for identifying and correcting root causes. If NYCHA is unable to comply with required timeframes, use best efforts to prioritize the scheduling and completion of these work orders.
- b. Ensure Skilled Trades staff are at their assigned locations according to the Skilled Trades neighborhood staffing schedule.
- c. Establish protocols for identifying and correcting root causes.
- d. Ensure staff are equipped with all necessary personal protective equipment (PPE) and adequate safety measures are followed.
- e. Inspect work in progress and completed work to ensure best practices are followed.
- f. Send Skilled Trades staffing schedule to the property maintenance supervisor and provide timely updates for each assigned Skilled Trades employee if there are any changes to the schedule.
- g. Notify the property maintenance supervisor when the work is completed and/or if additional Skilled Trades staff is required.
- h. Notify a neighborhood planner, borough planner, Skilled Trades deputy director, or administrator if a Skilled Trades employee is not able to complete a job because of waiting for necessary materials or a tenant not being home, and provide a new assignment within the building or development to the employee.
- i. Notify a neighborhood planner if a Skilled Trades employee observes any open unscheduled work orders for their trade in a unit in which they are assigned. Determine if the unscheduled work will proceed or request the neighborhood planner to reschedule to a later date if a Skilled Trades employee is not available.
- j. Perform regular inventory of in-stock materials and prepare order request for property managers, including:
 - (1) Check upcoming schedules to ensure that required materials are on hand when possible.

NYCHA STANDARD PROCEDURE MANUAL

- (2) Provide inventory reports to the neighborhood planner, borough planner, and Skilled Trades deputy director and administrator.
- (3) Send the materials list to the neighborhood and borough planners and provide an update on the materials that are in or out of stock.

C. Lead Hazard Control Department

1. The supervisor of the Abatement and Clearance Unit:
 - a. Oversees staff who perform large mold remediation jobs.
 - b. Coordinates scheduling work with the Technical Resources Environmental Field Operations Unit based on a daily Maximo query report which displays all mold work orders under the lead abatement worker (LAW) craft.
 - (1) Performs visual inspections of all mold units, documents inspections/attempts in Maximo with actuals, and attaches photos from before and after mold remediation.
 - (2) Communicates with residents and borough staff to establish target dates to begin the mold work.
 - (3) Assists Property Management Department staff with the issuance of NYCHA Form 042.727, *48 Hour Notice of Health and Safety Repairs*, after multiple unsuccessful attempts to gain access to an apartment.

NOTE:	After abatement work is complete, Property Management Department staff is responsible for coordinating and scheduling remaining repairs.
--------------	--

2. Abatement and Clearance Unit staff report apartments with popcorn ceilings that require asbestos testing to the Healthy Homes Department before mold remediation can begin.

D. Employees Who Remediate or Correct the Root Causes of Mold

All NYCHA employees who remediate or correct the root causes of mold:

1. Must follow the protocols in Sections VIII.D., Remediating Mold and Related Conditions – Apartments and Public Spaces, and VIII.E., Correcting Root Causes, below, and Appendix A, Remediation Methods, as applicable, when remediating mold and related conditions or correcting probable root causes.
2. Must use only a NYCHA-approved disinfectant or cleaning solution when remediating mold and related conditions. See Appendix B – HA Numbers for Mold Related Tools and Supplies, for a list of HA numbers for ordering supplies.

NYCHA STANDARD PROCEDURE MANUAL

E. All NYCHA Employees Performing Work in Apartments

Any NYCHA employee performing work in a resident apartment who observes a mold, excessive moisture, or water damage condition must create a parent mold inspection work order for every room with identified conditions on the handheld device or submit a paper mold work order to the Property Management office. For assistance on creating a parent mold inspection work order on the handheld device, see Appendix F – Creating a Mold Inspection in Apartments on the Handheld.

F. Compliance Department

The Compliance Department:

1. Ensures that all NYCHA employees comply with laws and regulations and that NYCHA is ethical in fulfilling its overall mission to provide safe, affordable housing to its residents.
2. Determines trends, performs data analyses, and ensures response actions are completed in accordance with this Standard Procedure.
3. Analyzes and investigates potential deviations from this Standard Procedure.
4. Performs analyses and assessments on mold and leak complaints submitted by internal and external stakeholders through the department's Complaint Forum on the NYCHA website.
5. Refers cases to the Environmental Health and Safety Department, the Customer Operations Department, Ombudsperson Call Center, and Quality Assurance Department.

G. Environmental Health and Safety Department

The Environmental Health and Safety Department:

1. Performs oversight inspections of mold work orders at NYCHA-owned and operated properties. Inspections include verifying the elimination of moisture and leaks, assessing the completeness of mold remediation, and evaluating the methods and materials used.
2. Responds to and investigates resident and employee complaints received through NYCHA's complaint forum or other communications regarding hazards that pose a threat to their health and safety including mold and other indoor air quality issues.
3. Issues corrective actions to NYCHA departments to address deficiencies identified during investigations and oversight. Corrective actions may include relocation of tenants or employees until hazards are abated.

NYCHA STANDARD PROCEDURE MANUAL

4. Provides recommendations to OMAR and NYCHA leadership for continuous improvement of mold management and indoor air quality, based on key observations and findings of investigations and routine oversight inspections.
5. Administers NYCHA's Respiratory Protection Program in accordance with NYCHA Standard Procedure 001:17:2, *NYCHA Respiratory Protection Safety Program*.
6. Oversees NYCHA's Hazard Communication Program including maintenance of the Safety Data Sheet database and initial safety trainings and refreshers to ensure NYCHA's compliance.

H. Ombudsperson Call Center

1. The Ombudsperson Call Center:
 - a. Is an independent third-party office for NYCHA residents to raise concerns regarding mold, leaks, and moisture conditions.
 - b. Holds NYCHA accountable for completing necessary mold and leak-related repairs in a timely manner.
 - c. Refers cases to the Office of Mold Assessment and Remediation, the Compliance Department, and the IMA to ensure that the root causes of mold and leaks are identified and remediated.
2. To ensure that NYCHA promptly addresses resident-reported mold and leak complaints, the Ombudsperson Call Center:
 - a. Interacts closely with residents.
 - b. Participates in targeted events that focus on consolidations that struggle the most with mold, leaks, and moisture issues and are part of NYCHA's specialized programs. This includes the Enhanced Oversight Program, which the Office of Mold Assessment and Remediation uses to create joint strategies to improve mold and leak compliance, address specific backlog issues, and assist with procurement.
 - c. Provides data to third parties regarding open complaints reported by residents.
 - d. Tracks scheduled repair dates and unscheduled repair dates.
 - e. Develops response timelines and escalation processes to ensure NYCHA responds to complaints from residents in a timely manner.
 - f. Facilitates regular status calls with NYCHA departments to discuss complaints from residents.

NYCHA STANDARD PROCEDURE MANUAL

I. Office of Mold Assessment and Remediation Mold Response Unit

The Mold Response Unit collaborates with the Ombudsperson Call Center by monitoring and case-managing complaints. The Mold Response Unit:

1. Tracks complaints from residents until resolution and confirmation of resident satisfaction.
2. Hosts check-ins with residents to inform them about the repair processes.
3. Bridges the gap in communication to ensure that repairs are completed as scheduled.
4. Informs residents about mold prevention through campaigns and targeted outreach.
5. Ensures the proper work orders are created and sequenced.
6. Escalates severe conditions for prioritization of scheduling or relocation.
7. Ensures root causes are identified and remediated.

J. Employees Who Manage Vendors That Perform Mold Remediation

1. NYCHA employees cannot assign a vendor mold remediation work order in excess of 10 square feet without first confirming that the vendor **and** vendor staff are certified and/or licensed to perform the required work, as required by New York State Department of Labor Article 32 guidelines for the Licensing of Mold Inspection, Assessment and Remediation Specialists and Minimum Work Standards (mold).

NYCHA STANDARD PROCEDURE MANUAL

- a. Each vendor assigned to perform repairs linked to mold-related conditions in excess of 10 square feet is required to hold a valid New York State Mold Remediator Company License. See sample below.

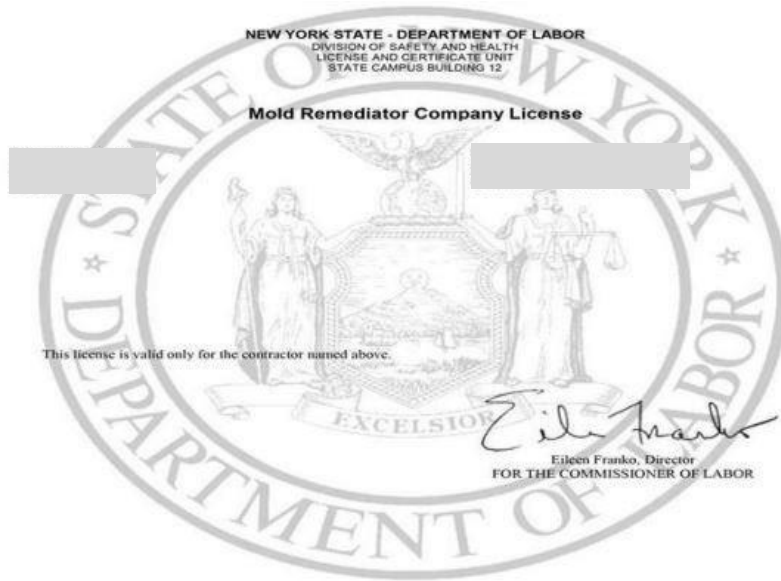

- b. Each vendor staff assigned to perform repairs linked to mold-related conditions in excess of 10 square feet is required to hold a valid New York State Mold Abatement Worker License. See sample below.



NYCHA STANDARD PROCEDURE MANUAL

2. Property managers, property maintenance supervisors, and assistant property maintenance supervisors:
 - a. Confirm that the vendor and all vendor staff performing work have the appropriate certification(s) and/or license(s) **before** assigning work order tickets. If the vendor does not provide the required certifications before the scheduled work date, the work must be rescheduled until the vendor provides the required certification(s).
 - b. Save copies of vendor and staff mold remediation licenses in the appropriate contract file for documentation purposes.
 - c. After the vendor comes onsite, check to confirm that the vendor's employees have a physical or electronic copy of their valid certification with them. If the vendor's employees cannot produce a copy of the certification, they cannot perform work.
 - (1) After NYCHA performs the visual inspection of the vendor employees' certifications, the vendor employees must write their name and certification identification number in the vendor logbook in the Property Maintenance Office. Then they can perform the work.
 - d. Ensure all vendor work is completed according to the scope of work.

NOTE:	Some work orders require firms and workers to have mold and Renovation, Repair and Paint (RRP) certifications. For example, if there is a mold remediation ticket that is in an apartment that requires RRP, the firms and workers must have both certifications/licenses. For more information, see NYCHA Standard Procedure 050:20:1, <i>Lead Safe Housing Procedure</i> .
--------------	---

VIII. PROCEDURE

A. Creating and Scheduling Mold Service Requests

1. Creating Parent Mold Work Orders

- a. Resident Service Requests to the Customer Contact Center (CCC) or Through the MyNYCHA App
 - (1) When a resident calls the Customer Contact Center (CCC) to make a service request involving mold or mildew, or submits a mold/mildew service request through the MyNYCHA App, a parent mold work order is created in Maximo.
 - (2) The Baez Consent Decree states that mold inspections must be performed within four days after creation of a work order. If NYCHA is unable to comply with this timeframe, NYCHA uses best efforts to prioritize the scheduling and completion of these work orders.

NYCHA STANDARD PROCEDURE MANUAL

- (3) The borough planner schedules the inspection. The property manager or assistant property manager reschedules missed appointments.
- (4) If NYCHA is not able to access the apartment to perform the inspection, the employee leaves NYCHA Form 042.727, *48-Hour Notice for Health and Safety Repairs*, stating that they will return to the apartment within 48 hours to reattempt to perform the inspection and may use right of entry to access the apartment for that purpose. See NYCHA Standard Procedure 040:17:3, *Accessing Public Housing Apartments When Tenant Not Home to Address Deficiencies Related to Leaks, Mold, and Lead-Based Paint, Tenant Not Home Interim Guidance (DGM20180005)*, and *Updated Tenant Not Home Guidance (October 23, 2023)*.

NOTE:	<ul style="list-style-type: none">• When residents are advised in the morning of a business day, the same day means that NYCHA will visit the apartment to attempt to perform the inspection by that afternoon. When residents are advised in the afternoon of a business day or on weekends or holidays, the same day means that NYCHA will visit the apartment to attempt to perform the inspection by the morning of the next business day.• See NYCHA Standard Procedure 040:09:6, <i>Customer Contact Center</i>, for information regarding the processing and scheduling of service requests through the CCC.
--------------	--

b. NYCHA Staff Initiates Mold Parent Work Orders

- (1) When property management staff or other NYCHA employees view mold conditions in a resident's apartment while performing other work or a mold inspection, they must:
 - (a) Create a parent mold work order in Maximo using the iWM app on the handheld device (See Appendix F – Creating a Mold Inspection in Apartments on the Handheld, for more information); or
 - (b) Complete and submit a paper Maximo mold work order to the Property Management Office the same day.
- (2) The property maintenance supervisor or assistant property maintenance supervisor ensures that property management office staff immediately creates a parent mold work order in Maximo from any submitted paper mold work order.

NOTE:	See Standard Procedure 040:09:7, <i>Managing Maintenance Work Orders</i> , for definitions of Siebel and Maximo; information on planning, completing, and closing out work orders in the Siebel and Maximo applications; and for the definitions of and relationships between parent and child work orders.
--------------	---

NYCHA STANDARD PROCEDURE MANUAL

2. Supervisory Review of All Mold Work Orders

- a. Property maintenance supervisors must review all mold work orders in Maximo at least once per day and assign inspections to themselves, assistant property maintenance supervisors, or maintenance workers who are trained to perform mold inspections.
- b. Neighborhood administrators must review all mold work orders weekly to ensure compliance with the mold service level agreement.
- c. If an initial mold inspection generated through a call to the CCC or in the MyNYCHA App is not scheduled, the property maintenance supervisor must assign an inspector to visit the apartment that same day to perform the initial mold inspection, or issue NYCHA Form 042.727, *48 Hour Notice of Health and Safety Repairs*, to the apartment.
- d. If an initial mold inspection created by NYCHA staff in Maximo is not scheduled, the property maintenance supervisor must:
 - (1) Contact the resident to schedule the appointment for the initial mold inspection within four calendar days from the parent work order creation date.
 - (2) If the resident is unable to schedule an appointment within four calendar days from the parent work order creation date, the property maintenance supervisor must advise the resident that:
 - (a) NYCHA will visit the apartment that same day in an attempt to perform the inspection; and
 - (b) NYCHA will return to the apartment within 48 hours to reattempt to perform the inspection if access is not granted and may use its Right of Entry to access the apartment. See NYCHA Standard Procedure 040:17:3, *Accessing Public Housing Apartments When Tenant Not Home to Address Deficiencies Related to Leaks, Mold, and Lead-Based Paint, Tenant Not Home Interim Guidance* (DGM20180005), and *Updated Tenant Not Home Guidance* (October 23, 2023).

NOTE:	Initial inspections must be scheduled for a date within four calendar days of the creation of the parent mold work order.
--------------	---

B. Inspecting Mold Conditions in Apartments

On the scheduled date provided on the parent mold work order, the inspector visits the resident's apartment to inspect the mold condition, identify the probable root cause(s), and determine appropriate next steps to remediate the mold, any related conditions, and correct the root cause(s).

NYCHA STANDARD PROCEDURE MANUAL

NOTE:	Initial mold inspections are performed using the handheld device. If a handheld device is not operating during the initial mold inspection, the inspector must record the inspection results on a Maximo paper mold inspection work order and immediately enter the results into Maximo following the initial mold inspection.
--------------	--

1. Preparing for the Initial Mold Inspection

Before visiting the apartment on the day of the initial mold inspection appointment, the inspector:

- a. Reviews the Maximo work order history for the apartment to determine if there is a history of mold or moisture problems that may be relevant to the current complaint.
- b. Checks the mold inspection tool kit to ensure that the following instruments are working: anemometer, hygrometer, and moisture meter.
- c. Assigns a maintenance worker to accompany them on the initial mold inspection, or to be on call, to immediately remediate mold and related conditions or to identify and correct root causes, when possible. The maintenance worker must bring an anemometer, borescope, HEPA vacuum, and appropriate tools for making wall-breaks. If the assigned inspector is a maintenance worker, they perform the inspection alone; a second maintenance worker does not go with them.
- d. Must call the resident when they are on the way to the initial mold inspection to remind them of the inspection. If the resident does not answer the call, the inspector still must go to the apartment at the scheduled time.

NOTE:	If the resident or other adult is not home to allow access to the apartment for a scheduled mold related appointment, see NYCHA Standard Procedure 040:17:3, <i>Accessing Public Housing Apartments When Tenant Not Home to Address Deficiencies Related to Leaks, Mold, and Lead-Based Paint, Tenant Not Home Interim Guidance</i> (DGM20180005), and <i>Updated Tenant Not Home Guidance</i> (October 23, 2023).
--------------	--

After following the tenant not home policy, NYCHA performs an initial mold inspection, and the inspector leaves the following in the apartment:

- NYCHA Form 060.303, *Controlling Mold in Your Apartment*
- NYCHA Form 060.845, *Mold Inspection Report*
- A hard copy of the work order

NYCHA STANDARD PROCEDURE MANUAL

2. Discussing the Mold Conditions with the Resident

Upon arriving at the apartment, the inspector:

- a. Makes best efforts to interview an adult listed on the household composition about any history of mold and moisture in the apartment that may be relevant to the current complaint.
- b. Adds the information to the handheld device if there is a history.

3. Performing the Initial Mold Inspection

The inspector performs the initial mold inspection using the handheld device.

- a. While inspecting for mold, water damage, and moisture, the inspector:
 - (1) Visually inspects the room or area identified in the mold work order for mold growth and records the total estimated square footage of mold on room walls (1-4), floor, ceiling, and any components such as kitchen cabinetry.
 - (2) Visually inspects the room for water damage and records the location of the water damage (the specific wall(s), floor, ceiling, or component).
 - (a) Use a standard letter-sized paper (8 ½ x 11) in the photo(s) uploaded as a way to show perspective of the amount of mold.
 - (3) Uses the moisture meter to measure the walls, floor, ceiling, and components in the room for subsurface moisture and records the measurement, including whether it is equal to or greater than 599 (a wet measurement), or less than 599. See Appendix E – Instructions for Using a Moisture Meter.
 - (a) Takes multiple measurements of each surface or component and records if a measurement is equal to or greater than 599.
 - (b) Inspects the chase wall, or any other areas displaying water damage, and all surrounding areas, such as the ceiling, floors, and other walls.
 - (c) Records the highest moisture water reading for each affected surface in the room, whether the water damage or mold can be seen or not (for example, Wall 1, Wall 2, Ceiling, etc.):
 - i. If the surface shows visible water damage or mold growth, the moisture meter reading should be taken in intervals of six inches in each direction, horizontally and vertically, and continued to the point of at least two feet beyond any visible water damage or mold growth until the moisture meter reading is less than 599.

NYCHA STANDARD PROCEDURE MANUAL

- ii. If the surface shows no visible water damage or mold growth, the moisture meter reading should be taken in intervals of one foot in each direction.

NOTE:	The moisture meter must be held flush against the wall and not held at an angle while taking measurements.
--------------	--

b. General Evaluation of Room Conditions

If a mold, water damage, or moisture (a wet measurement) condition is found, the inspector must perform a general evaluation of the room and the opposing common walls in adjoining rooms and common areas.

NOTE:	When evaluating the opposing side of common walls in adjoining rooms and common areas, the inspector creates a parent mold work order on the handheld device if mold conditions are identified in an adjoining room that are not likely from the same root cause. The inspector should complete this mold work order for the adjoining room at the time of the initial mold inspection.
--------------	--

The inspector:

- (1) Records the surface structure (for example concrete, plaster, sheetrock) and framing structure (wood, steel) of the room's walls, floor, ceiling, and component(s).
- (2) Uses the hygrometer to take a humidity reading of the room and records the humidity level.
- (3) If the room is a kitchen or bathroom, indicates if there is mechanical ventilation.
 - (a) If there is mechanical ventilation, the inspector checks the ventilation by using the anemometer to take an air flow measurement in cubic feet per minute and records the result in the handheld device.
 - (b) If the cubic feet per minute is less than 25, Maximo automatically generates child work orders to clean the horizontal vent duct work and to check the roof fan.

NOTE:	The user must ensure the anemometer is calibrated properly by entering the correct height and width in inches of the exhaust duct and ensuring the free air percentage is set to 55%. See Appendix D – Instructions for the New Version of the Testo App for instructions on how to use the anemometer. Users must follow the manufacturer's instructions when using inspection tools.
--------------	--

NYCHA STANDARD PROCEDURE MANUAL

- (c) If there is a window:
 - i. The inspector checks that the window is operating properly and records the result in the handheld device.
 - ii. Maximo automatically generates a child work order to repair the window if it is not operating properly.
- (d) If there is no window, the inspector does not answer the question and does not indicate “no” on the work order.
- (e) If there is no exhaust fan, the inspector does not answer the question and does not indicate “no” on the work order.

(4) If the room is a bathroom:

- (a) Checks if the toilet base and shower enclosure are caulked and records the results in the handheld device.
- (b) Maximo automatically generates a child work order to caulk the toilet base and/or shower enclosure if they are not caulked.

(5) Visually inspects the room for signs of pest infestation and records the results in the handheld device.

- (a) Maximo automatically generates a child work order for an exterminator when there is evidence of pests.

NOTE:	If an employee identifies potential asbestos in a unit, they refer to Compliance Advisory Alert #34 (Addendum), <i>Asbestos Containing Material In Apartments</i> , and continue performing the inspection.
--------------	---

c. Identifying the Probable Root Cause(s) and Remediation Methods

The inspector determines the probable root cause(s) for any wall, floor, ceiling, or component identified in Section VIII.B.3.a. above as having mold, water damage, or moisture (a wet measurement).

- (1) The inspector selects on the handheld device a probable root cause as listed in the following chart. Up to four causes can be selected.

NYCHA STANDARD PROCEDURE MANUAL

Root Cause of Mold or Mildew Inspection Drop-Down	Definition Pop-Up Upon Initial Selection	Definition on the Resident's Remediation Plan
Bathtub Shower Issues	Selected when the cause of mold, water damage, or wet condition is related to any of the following issues: bathtub missing, faucet leaking, faucet running, faucet dripping, etc.	The cause of mold, water damage, or wet condition is related to any of the following issues: bathtub missing, faucet leaking, faucet running, faucet dripping, etc.
Caulking DML (Maintenance)	Selected when mold, water damage, or moisture is found in a bathroom or adjacent room due to water penetrating through missing or damaged areas of the bathtub/shower caulking.	The mold is caused when water is penetrating through missing or damaged areas of the bathtub/shower caulking.
Grouting DML (Bricklayer)	Selected when mold, water damage, or moisture is found in a bathroom or adjacent room due to water penetrating through missing or damaged areas in the shower/bathtub grouting resulting in the need to replace tiles.	The mold is caused by moisture penetrating through the cracks of the tiles due to lack of grouting resulting in the need to replace tiles.
Grouting DML (Plasterer)	Selected when mold is found in a bathroom around the tub surround requiring a carpenter's corrective action prior to a plasterer's replacement/ installation of grout.	The mold is found in a bathroom around the tub surround requiring a carpenter's corrective action prior to a plasterer's replacement/ installation of grout.
Grouting/Caulking DML (Plasterer)	Selected when moisture is regularly pooling around a bathtub due to a lack of caulking which could cause grout chipping or tiles falling.	The moisture is regularly pooling around a bathtub due to a lack of caulking which could cause grout chipping or tiles falling.
Grouting/Caulking DML (Bricklayer)	Selected when mold is found in the areas where there is missing mortar which allows water to penetrate the building.	The mold is found in the areas where there is missing mortar which allows water to penetrate the building.
Leak Around Window	Selected when there is visible mold, water damage, or moisture around the window due to lack of sealant around	There is visible mold, water damage, or moisture around the window due to lack of sealant around the window,

NYCHA STANDARD PROCEDURE MANUAL

	the window, thereby causing water to penetrate.	thereby causing water to penetrate.
Leak From Above - Previously Identified	Selected when the root cause of the mold or water damage was identified or corrected by Property Maintenance or Skilled Trades staff on a prior work order.	When the root cause or remediation work for the mold condition was identified or corrected by Property Maintenance or Skilled Trades staff on a prior work order.
Leak Through Façade	Selected when mold, water damage, or moisture is caused by water penetration through a crack or damaged/missing mortar on an exterior wall.	When mold, water damage, or moisture is caused by water penetration through a crack or damaged/missing mortar on an exterior wall).
Leak From Above/ Beside Investigate	Selected when there is visible mold or water damage caused by an active leak from a unit above or beside complaint unit. A best effort to trace the leak and identify the source should be made during the initial mold inspection.	There is visible mold or water damage caused by an active leak from a unit above or beside the complaint unit.
Other	Selected if the root cause is not listed or not evident through the standard assessment practices. A detailed explanation of visible conditions is required in Notes and attached relevant photographs.	Based on the inspector's findings, they document in Notes the root cause(s) and attach relevant photograph(s).
Pipe Insulation DML	Selected when mold is caused due to pipes sweating because of lack or improper pipe insulation in the wall.	Mold is caused due to pipes sweating because of lack or improper pipe insulation in the wall.
Perimeter Surface Condensation	Selected when the mold or water damage is caused by warm air in the apartment coming into contact with relatively colder building surfaces (during cold outdoor weather), which results in condensation (sweating) on perimeter walls, adjacent ceiling surfaces, and concrete structural beams/columns.	Problems can be distinguished from exterior facade leaks by the absence of wet readings and the absence of damage on the underlying substrate (e.g., no blistering of plaster or efflorescence). Water spots/staining and/or visible moisture/ sweating may also be present.

NYCHA STANDARD PROCEDURE MANUAL

Plumbing Leak - In Unit	Selected when the mold, water damage, or moisture condition is caused by a pipe leaking within the wall cavity. A wall break is required to diagnose the problem.	The mold issue was caused by a pipe leaking through the wall cavity.
Resident-Caused	Selected if the reported mold and/or saturated building materials were caused by a resident's actions or inactions (e.g., overflowing/clogged toilet or sink, not opening the window for ventilation during or after a shower, improper installation of the dishwasher or washing machine, covering the vent, making use of a dryer in the apartment, etc.).	Mold and/or saturated building materials were caused by a resident's actions or inactions (e.g., overflowing/clogged toilet or sink, not opening the window for ventilation during or after a shower, improper installation of the dishwasher or washing machine, covering the vent, making use of a dryer in the apartment, etc.).
Resident-Caused - Code 1	The handheld prompts the user to select the applicable code.	Resident instructed to open the window for ventilation during a shower and leave the window open for a time after the shower to assist with ventilation.
Resident-Caused - Code 2	The handheld prompts the user to select the applicable code.	Resident instructed to contact a repair service for the dishwasher and to not use the dishwasher until it can be properly repaired/connected.
Resident-Caused - Code 3	The handheld prompts the user to select the applicable code.	Resident instructed to contact a repair service for the washing machine and to not use the washing machine until it can be properly repaired/connected.
Resident-Caused - Code 4	The handheld prompts the user to select the applicable code.	Resident instructed to remove item(s) blocking the vent cover.
Resident-Caused - Code 5	The handheld prompts the user to select the applicable code.	Clothing dryer was installed improperly.
Resident-Caused - Code 6	The handheld prompts the user to select the applicable code.	Based on the inspector's findings, they document in Notes the root cause(s) and attach relevant photograph(s).

NYCHA STANDARD PROCEDURE MANUAL

Roof Fan Out of Order	Selected when the mold condition is caused by inadequate exhaust due to an out of order roof fan. This is confirmed following an inspection of the roof fan.	The mold condition is caused by inadequate exhaust due to an out of order roof fan.
Roof Leak-Non-Capital	Selected when the mold, water damage, or moisture condition is caused by a leak from the roof and a replacement or repair of a portion of the roof is required.	The mold or water damage is caused by a leak from the roof and a replacement or repair of a portion of the roof would be required.
Sink Supply Line Leak	Selected when the mold, moisture condition, or water damage is caused by a leak in the supply line.	The mold, moisture condition, or water damage is caused by a leak in the supply line.
Sink Waste Line Leak	Selected when the mold, moisture condition, or water damage is caused by a leak(s) in the waste line.	The mold, moisture condition, or water damage is caused by a leak(s) in the waste line.
Toilet Leak	Selected when the mold, moisture condition, or water damage was caused by an active leak coming from the toilet.	The mold, moisture condition, or water damage was caused by an active leak coming from the toilet.
Toilet Bowl/Tank Needs Barrier	Selected when the mold, moisture condition, or water damage is caused by condensation (sweating) on the toilet bowl/tank, resulting in moisture being transferred to the adjacent wall surfaces.	The mold, moisture condition, or water damage is caused by a toilet that runs continuously resulting in condensation (sweating) on the toilet bowl/tank, resulting in moisture being transferred to the adjacent wall surfaces.
Tub Surround DML	Selected when mold, moisture condition, or water damage is found in a bathroom or adjacent room due to water penetrating through missing or damaged areas of the tub surround that require repair or replacement.	The mold, moisture condition, or water damage is caused by water penetrating through missing or damaged areas of the tub surround that require repair or replacement.
Vent Clogged/Covered	Selected when the mold condition is caused by inadequate exhaust ventilation due to the exhaust grill or lateral being clogged or covered by	The mold condition is caused by inadequate exhaust ventilation due to the exhaust grill or lateral being clogged or covered by someone/something other

NYCHA STANDARD PROCEDURE MANUAL

	someone/something other than the resident, dust accumulation, or the grill painted over.	than the resident, dust accumulation, or the grill painted over.
Window Inoperable	Selected when the mold condition is caused because of lack of ventilation due to the window's inability to open.	The mold condition is caused because of lack of ventilation due to the window's inability to open.

(2) The inspector then:

- (a) Selects the ceiling, wall(s), floor, or component(s) identified in Section VIII.B.3.a. above that have the same probable root cause (for example, both the mold on the ceiling and water damage on the wall have a probable root cause of Shower Moisture).
- (b) Indicates if a wall break is required to inspect or correct the probable root cause.
 - i. If a wall break is required, the inspector must perform the wall break with the assistance of a maintenance worker as part of the initial mold inspection.
 - aa. Create a one-square foot opening behind the medicine cabinet to provide the best access to visibly inspect the wall cavity. If temporary repairs are needed, they must be performed.
 - bb. If a larger wall break is needed to identify the root cause, it must be performed.
 - ii. Maximo automatically creates a work order and on that work order is a banner to alert staff if they are required to follow the Renovation, Repair, and Painting (RRP) rules. For more information, see NYCHA Standard Procedure, 050:20:1, *Lead Safe Housing Procedure*.

NOTE:	Lead-safe work practices and RRP certified workers must be used if (i) Maximo identifies that RRP work is required (the apartment is presumed or known to contain lead-based paint) <u>and</u> (ii) any work would disturb more than 2 square feet of a painted surface per room, or more than 10 percent of the total surface area on an interior or exterior type of component with a small surface area.
--------------	---

- (c) If the probable root cause is **not** Resident – Cause:
 - i. Selects one or more Failure Class/Problem Codes, as applicable, from the options in the dropdown menu for that probable root cause.

NYCHA STANDARD PROCEDURE MANUAL

- ii. Selects the appropriate craft required to make the repair for each Failure Class/Problem Code selected.

(d) If the probable root cause **is** Resident – Cause

- i. Selects on the handheld device the specific instruction provided to the resident in Section VIII.B.5. below for each probable root cause that is Resident – Cause.
- ii. Selects the remediation method and craft from the options in the dropdown menu for the selected wall(s), floor, ceiling, or component(s).

(3) Maximo automatically generates child work orders for the Failure Class/Problem Codes (except when the probable root cause is Resident – Cause) and the remediation methods selected.

(4) If there are any additional probable root causes, the inspector repeats the steps in Section VIII.B.3.c.(1) above for each probable root cause.

(5) If the inspector is unable to determine the probable root cause of a mold, water damage, or moisture (wet measurement) condition they contact their supervisor. If the cause still cannot be determined, they must immediately contact the Office of Mold Assessment & Remediation by e-mail at mold.busters@nychca.nyc.gov.

d. Completing the Initial Mold Inspection

To complete the initial inspection the inspector:

- (1) Takes photo(s) of the condition(s) identified, including multiple close-up photos from different angles of the condition(s) and at least one photo of the larger area, using the handheld device and uploads the photo(s) into the parent work order in Maximo. See Appendix C – Sample Photos of Mold Conditions.
- (2) Selects the appropriate craft required to make the repair for each Failure Class/Problem Code selected.

NOTE:	For clarity, the inspector must record key information obtained during the inspection in the Notes field of the iWM app on an unfounded work order.
--------------	---

4. Reviewing the Work Plan

After completing the initial mold inspection, the inspector:

- a. Reviews the child work orders (the work plan) in the handheld device to confirm the work plan is correct and complete.

NYCHA STANDARD PROCEDURE MANUAL

b. Identifies the outcomes of the mold inspection on NYCHA Form 060.845, *Mold Inspection Receipt*.

5. Reviewing the Initial Inspection Results with the Resident

a. When Mold, Water Damage, or a Moisture Condition is Identified

The inspector:

- (1) Gives NYCHA Form 060.303, *Controlling Mold in Your Apartment*, to the resident and reviews with the resident the general recommendations on the form for preventing and cleaning mold and the importance of identifying and correcting the root cause(s) of mold to avoid recurrence.
- (2) Gives NYCHA Form 060.845, *Mold Inspection Receipt*, to the resident and reviews the following with the resident:
 - (a) The initial mold inspection outcome and the inspection's findings (founded or unfounded).
 - (b) The requirement that NYCHA perform a quality assurance mold inspection between 30-45 calendar days after all work is completed.
 - (c) The required timeframe for the completion of all work.
 - (d) The name and contact information of the ombudsperson.
- (3) Indicates in the handheld device that NYCHA Form 060.845, *Mold Inspection Receipt*, was provided to and discussed with the resident.
- (4) Advises the resident to contact the neighborhood planner to coordinate any follow-up appointments needed for the following skilled trades:
 - (a) Bricklayers
 - (b) Carpenters
 - (c) Electricians
 - (d) Exterminators
 - (e) Glaziers
 - (f) Painters
 - (g) Plasterers

NYCHA STANDARD PROCEDURE MANUAL

- (h) Plumbers
- (i) Roofers

NOTE:	If the resident does not contact the neighborhood planner, the neighborhood planner schedules the work anyway and makes best efforts to contact the resident. They check the child work orders twice a week and determine when to schedule them.
--------------	--

(5) Advises the resident that NYCHA will mail them NYCHA Form 060.846, *Mold Inspection Review*, which details the following information:

- (a) The initial mold inspection and probable root cause findings.
- (b) The next step(s) to remediate the mold, excessive moisture, or related condition and correct the root cause.
- (c) The specific instruction(s) on how to correct the probable root cause if the probable root cause is Resident – Cause.
- (d) The requirement that NYCHA perform a quality assurance mold inspection between 30-45 calendar days after all work is completed.
- (e) The required timeframe for the work.
- (f) The name and contact information of the ombudsperson.
- (g) The contact information for the neighborhood planner and Property Management Office to schedule repairs.

NOTE:	See Management Manual, Chapter II, Rent and Rent Collection, for details on when and how to make a social service referral to the Family Partnerships Department if there are housekeeping or safety hazards in an apartment.
--------------	---

b. When the Mold Condition is Unfounded

The inspector:

- (1) Discusses the initial inspection findings with the resident.
- (2) Gives NYCHA Form 060.303, *Controlling Mold in Your Apartment*, to the resident and reviews with the resident the general recommendations on the form for preventing and cleaning mold and the importance of identifying and correcting the root cause(s) of mold to avoid recurrence.

NYCHA STANDARD PROCEDURE MANUAL

- (3) Requests that the resident sign the unfounded work order on the handheld device.
- (4) Indicates in the handheld device if the resident refused to sign or if the resident disagrees that the mold condition is unfounded.
- (5) Provides the resident with NYCHA Form 060.845, *Mold Inspection Receipt*, including the name and contact information of the ombudsperson.
- (6) Closes the mold work order as unfounded.
- (7) Provides the name and contact information of the ombudsperson.
- (8) Takes photos of the condition(s) reported by the resident as mold, including multiple close-up photos from different angles of the condition(s) and at least one photo of the larger area, and uploads them to the parent work order in Maximo. See Appendix C – Sample Photos of Mold Conditions.

NOTE:	<p>Some of the more common errors when an inspector performs an inspection include:</p> <ul style="list-style-type: none">• Improperly performing wet measurements.• Marking inspections as unfounded and partial or incomplete water damage assessments.• Improperly identifying root causes.• Improper or insufficient documentation. <p>For more information, see Compliance Advisory Alert #55, <i>Common Errors When Conducting Mold Inspections</i>, on NYCHA Connect.</p>
--------------	---

C. Inspecting Mold Conditions in Public Spaces and Other Non-Residential Spaces

1. To inspect mold in public spaces or other non-residential spaces, an employee who observes mold creates a parent CM work order on the handheld. If the employee does not have the ability to create a work order on the handheld, they inform the property maintenance supervisor. For assistance on creating a parent mold inspection work order on the handheld device, see Appendix G – Creating a Mold Inspection in Public Spaces and Other Non-Residential Spaces on the Handheld.
2. The inspector:
 - a. Performs the mold inspection and records their observations in the work order log, including the square footage of mold and moisture readings.
 - b. Takes photo(s) of the conditions(s) identified, including multiple close-up photos from different angles of the conditions(s) and at least one photo of the larger area, using a handheld device. Use a standard letter-sized paper (8 ½ x 11) in the

NYCHA STANDARD PROCEDURE MANUAL

photo(s) as a way to show perspective of the amount of mold. See Appendix C – Sample Photos of Mold Conditions.

3. If mold is identified, the property maintenance supervisor or employee who responds to the work order creates a parent work order under failure class "MILDEWCONDITION" and problem code "MILDEW". They generate child work orders for mold remediation and repair tasks under the parent work order.

D. Remediating Mold and Related Conditions – Apartments, Public Spaces, and Other Non-Residential Spaces

NOTE:	See Appendix B for a list of HA numbers for ordering specialized tools and supplies.
--------------	--

1. All remediation work must conform to the protocols in the following documents:
 - a. NYCHA Standard Procedure 050:20:1, *Lead Safe Housing Procedure*
 - b. Appendix A, Remediation Methods
 - c. *Interim Guidance on Wall Breaks*
 - d. *Interim Guidance on Pipe Insulation*

NOTE:	If cracked or crumbling 9-inch by 9-inch vinyl floor tile is present, staff must: <ul style="list-style-type: none">• Cover the exposed area of floor with plastic• Tape all edges securely with duct tape• Instruct the resident not to disturb the covered area• Contact the Asbestos Department for further instructions
--------------	--

NYCHA STANDARD PROCEDURE MANUAL

2. Titles Performing Remediation Based on Amount of Mold

Work orders for mold cleaning are created under the Mildew Condition/Needs Cleaning failure class/problem code combination.

Amount of Mold	Title That Performs Remediation
Up to 10 square feet in a room, in developments flagged in Maximo as being a lead development	Caretaker X
Up to 20 square feet in a room, in developments or units not flagged in Maximo as being a lead development or unit	Caretaker X
More than 10 square feet in a room, but less than 100 square feet, in developments or units flagged in Maximo as being a lead development or unit	Painter
More than 20 square feet in a room, but less than 100 square feet, in developments or units not flagged in Maximo as being a lead development or unit	Painter
Equal to or more than 100 square feet in a room	Lead Abatement Worker

3. List of Public Spaces and Other Non-Residential Spaces

NOTE:	Work orders for public spaces and other non-residential spaces are created in Maximo based on the locations listed below, not based on building(s) or floor(s).
--------------	---

Auditorium	Basement	Commercial space
Community center	Compactor room	Control room
Daycare center	Depot	Electrical room
Foyer	Garage	Gas meter room
Gym	Hallway	Head Start
Lobby	Locker	Mechanical room
Meter room	Office	Pantry
Police Service Area	Pump room	Room
School	Senior center	Shop room
Stairhall	Stairwell	Storage
Storeroom	Viper room	

4. Personal Protective Equipment (PPE)

NOTE:	Employees using respirators also must follow the requirements in NYCHA Standard Procedure 001:17:2, <i>Respiratory Protection Safety Program</i> .
--------------	--

NYCHA STANDARD PROCEDURE MANUAL

a. Large Remediation Jobs Performed by Lead Abatement Workers or Certified Contractors

Employees must use the following:

(1) A full facepiece respirator with P-100 filters used in accordance with the OSHA respiratory protection standard (29 CFR 1910.134).

(a) The full facepiece respirator also may be used as part of a powered air purifying respirator (PAPR) system.

(2) Disposable protective clothing covering both head and shoes.

(3) Gloves.

(4) Eye protection.

b. Mold Remediation Jobs of Less Than 100 Square Feet

Employees must use the following:

(1) An N95 disposable respirator such as a dust mask or more protective respirator (such as an N100 disposable respirator) in accordance with the OSHA respiratory protection standard (29 CFR 1910.134)

(2) Disposable protective clothing covering both head and shoes

(3) Gloves

(4) Eye protection

NOTE:	NYCHA employees who perform oversight and construction project management inspections during active mold remediation (whether performed by NYCHA employees or vendors) must follow the PPE requirements listed directly above.
--------------	--

5. All work must be documented with photographs of the completed mold remediation process.

NOTE:	Employees can contact the Environmental Health and Safety Department at ehs@nych.nyc.gov if guidance is needed on PPE recommendations or requirements.
--------------	--

E. Correcting Root Causes

1. Employees must ensure that all repairs to correct root causes:

NYCHA STANDARD PROCEDURE MANUAL

- a. Are completed to NYCHA standards.
- b. Conform to the protocols in the following documents:
 - (1) NYCHA Standard Procedure 050:20:1, *Lead Safe Housing Procedure*
 - (2) NYCHA Standard Procedure 050:21:1, *Roof Fan Inspections at NYCHA Residential Buildings*
 - (3) Interim Guidance for Leak Work Orders for Maintenance Workers (June 15, 2023)
- c. Are documented with photographs per the guidelines in Section VIII.C.4. above.

2. Instructions for Cleaning Horizontal Vent Ductwork

When cleaning horizontal vent ductwork from inside the apartment, employees remove the face of the grill to the vertical shaft and HEPA-vacuum the grill and the interior and exterior of the horizontal vent ductwork.

F. Time Frames to Respond to Mold and Related Issues

1. Service Level Goals

- a. Flooding conditions must be abated within 24 hours of the initial complaint provided that NYCHA has access to the impacted areas. All standing water relating to the flood must be removed, and water-soaked areas, except for residents' personal property, must be dried within 48 hours of the initial complaint. Residents must be advised to clean and dry any damp furnishing and other personal property within 24-48 hours.
- b. Initial Mold Inspection and Child Work Orders
 - (1) Simple repairs must be completed within seven calendar days from the date the parent mold work order was created. Complex repairs must be completed within 15 calendar days from the date the parent mold work order was created. If NYCHA is unable to comply with these timeframes, NYCHA uses best efforts to prioritize the scheduling and completion of these work orders.
 - (2) Given the timeframe directly above in b.(1)., the initial mold inspection must be completed within four calendar days from the date the parent mold work order was created.
 - (3) These standards may be reviewed and updated based on performance.
- c. Quality Assurance Mold Inspections

NYCHA STANDARD PROCEDURE MANUAL

The quality assurance mold inspection must be completed between 30-45 calendar days after the last child work order has been closed.

G. Reasonable Accommodations

See Standard Procedure 040:12:1, *Reasonable Accommodations in Housing for Applicants, Public Housing Residents, and Section 8 Voucher Holders*, to learn more about the responsibilities of NYCHA staff to review reasonable accommodation requests, and the applicable terms, forms, and policies for reasonable accommodations.

H. Quality Assurance

1. Quality Assurance Mold Inspections – Apartments

- a. Maximo automatically generates a quality assurance mold inspection work order 25 calendar days after the last child work order is closed for all apartments where a mold, water damage, or moisture (wet measurement) condition was identified during the inspection. The target start date is populated automatically as 30 calendar days after the last child work order is closed and the target end date is populated as 45 calendar days after the last child work order is closed.
- b. After the quality assurance mold inspection work order is generated, the property maintenance supervisor:
 - (1) Makes best efforts to assign a different person to perform the quality assurance mold inspection than performed the initial mold inspection. They can assign themselves, assistant property maintenance supervisor, property manager, or a maintenance worker who is certified in mold inspections to perform the quality assurance mold inspection.
 - (2) Ensures that Property Management staff contacts the resident and schedules the quality assurance mold inspection to take place between 30-45 calendar days after the last child work order is closed.

NOTE:	<ul style="list-style-type: none">• For quality assurance purposes, the Property Management Department makes best efforts to have the inspector performing the quality assurance mold inspection be different than the inspector who performed the initial mold inspection.• Quality assurance mold inspections are performed using the handheld device. If a handheld device is not operating during the quality assurance mold inspection, the inspector must record the results on a paper quality assurance mold inspection work order and enter the results into Maximo immediately following the quality assurance mold inspection.
--------------	--

NYCHA STANDARD PROCEDURE MANUAL

c. Preparing for the Quality Assurance Mold Inspection

Before visiting the apartment on the day of the quality assurance mold inspection appointment, the inspector:

- (1) Checks the mold inspection tool kit, to ensure that the following instruments are in working order: anemometer, hygrometer, and moisture meter.
- (2) Brings all the tools in the mold inspection tool kit to the quality assurance mold inspection in case a full new initial mold inspection is needed.
- (3) When feasible, assigns a maintenance worker to accompany them on the quality assurance mold inspection or be on call in case there is follow-up work or a full new initial mold inspection is required. The maintenance worker must bring a borescope and tools appropriate for making wall breaks. If the assigned inspector is a maintenance worker, they perform the inspection alone; a second maintenance worker does not go with them.
- (4) Calls the resident when they are on the way to the quality assurance mold inspection to remind them of the appointment. If the resident does not answer the call, the inspector still must go to the apartment at the scheduled time.

d. Performing the Quality Assurance Mold Inspection for Mold, Water Damage, and Moisture

The inspector:

- (1) Visually inspects for mold on any wall, floor, ceiling, or component in the complaint room and records the results in the handheld device.
- (2) Visually inspects for water damage on any wall, floor, ceiling, or component in the complaint room and records the results in the handheld device.
- (3) Uses the moisture meter to measure for subsurface moisture on any wall, floor, ceiling, or component in the complaint room and records the results in the handheld device.
 - (a) If mold, water damage, or moisture (a wet measurement) is found during the quality assurance mold inspection, the inspector:
 - i. Fails the quality assurance mold inspection and closes the quality assurance mold inspection work order. Maximo automatically generates a new related mold work order (re-inspection).
 - ii. Immediately performs a full mold inspection following the steps in Section VIII.B.3-5.

NYCHA STANDARD PROCEDURE MANUAL

- (b) If no mold, water damage, or moisture (wet measurement) is found, the inspector continues with the quality assurance mold inspection.
- (4) If an air flow measurement was taken during the initial mold inspection, uses an anemometer to take an air flow measurement in cubic feet per minute of the kitchen or bathroom exhaust vent.

NOTE:	The user must ensure the anemometer is calibrated properly by entering the correct height and width in inches of the exhaust duct and ensuring the free air percentage is set to 55%. See Appendix D – Instructions for the New Version of the Testo App for instructions on how to use the anemometer. Users must follow the manufacturer’s instructions when using inspection tools.
--------------	--

- (5) Confirms that all work (child work orders) to remediate mold and correct root causes and related conditions was completed satisfactorily.
 - (a) Reviews the work actuals in Maximo of the child work orders using the handheld device.
 - (b) Visually inspects all completed work in the apartment related to the child work orders.
 - (c) If all work was completed satisfactorily completes the quality assurance inspection by taking photo(s) of the entire inspection area(s) free of mold, water damage, and/or moisture, including multiple close-up photos from different angles of the area(s) and at least one photo of the larger area, and uploading the photo(s) into Maximo. See Appendix C – Sample Photos of Mold Conditions.
 - (d) If any work was not completed satisfactorily:
 - i. Immediately creates a child work order in Maximo.
 - ii. Takes and uploads multiple photographs of any visible mold, water damage, and/or moisture as identified during the quality assurance mold inspection. Photos taken during the quality assurance mold inspection can be identified by being attached to the quality assurance work order.
 - iii. Closes the existing quality assurance mold inspection work order.
 - iv. Follows up with supervisor of the staff person(s) who performed the work to report the unsatisfactory work and ensure the work is completed.

NOTE:	See Section XII, Non-Compliance, for steps to address work that is not performed to standards.
--------------	--

NYCHA STANDARD PROCEDURE MANUAL

e. Reviewing the Quality Assurance Mold Inspection with the Resident

(1) Quality Assurance Mold Inspection Complete – All Work Satisfactorily Completed

The inspector:

- (a) Reviews the quality assurance inspection findings with the resident.
- (b) Requests that the resident sign the quality assurance mold inspection work order on the handheld device confirming that mold and any related conditions are not present and that all work was completed satisfactorily.
- (c) Indicates on the handheld device if the resident refuses to sign or is dissatisfied with the work.
- (d) Closes the quality assurance mold inspection work order.

(2) Additional Work Needed

If additional work is needed, the inspector advises the resident of:

- (a) The next steps to complete the work and the required timeframe for completion of all work.
- (b) The requirement for a new quality assurance mold inspection after the work is completed.

2. Quality Assurance Mold Inspections – Public Spaces and Other Non-Residential Spaces

a. Performing the Quality Assurance Mold Inspections

- (1) The property maintenance supervisor creates a quality assurance mold inspection work order for all areas where a mold, water damage, or moisture (wet measurement) condition was identified during the initial mold inspection. The target start date must be populated as 30 calendar days after the last child work order is closed and the target end date is populated as 45 calendar days after the last child work order is closed.
- (2) After the quality assurance mold inspection work order is created, the property maintenance supervisor:
 - (a) Assigns themselves, the assistant property maintenance supervisor, property manager, or a maintenance worker who is certified in mold inspections to perform the quality assurance mold inspection. For quality assurance purposes, the property maintenance supervisor makes best efforts to have

NYCHA STANDARD PROCEDURE MANUAL

the inspector performing the quality assurance mold inspection be different than the inspector who performed the initial mold inspection.

- (b) Ensures that Property Management staff schedules the quality assurance mold inspection to take place between 30-45 calendar days after the last child work order is closed.

b. Preparing for the Quality Assurance Mold Inspection

Before visiting the area on the day of the quality assurance mold inspection appointment, the inspector:

- (1) Searches for the scheduled mold work order number in Maximo.
- (2) Reviews previous mold-related work done in the area.
- (3) Checks the mold inspection tool kit to ensure that the following instruments are in working order: anemometer, hygrometer, and moisture meter. Brings all the tools in the mold inspection tool kit to the quality assurance mold inspection in case a full new initial mold inspection is needed.
- (4) When feasible, assigns a maintenance worker to accompany them on the quality assurance mold inspection or be on call in case there is follow-up work or a full new initial mold inspection is required. The maintenance worker must bring a borescope and tools appropriate for making wall breaks.

c. Performing the Quality Assurance Mold Inspection

The inspector:

- (1) Starts the inspection by clicking "Inspection" in iWM app.
- (2) Visually inspects for mold on any wall, floor, ceiling, or component identified in the initial mold inspection as having mold and records the results in the handheld device.
- (3) Visually inspects for water damage on any wall, floor, ceiling, or component identified in the initial mold inspection as having water damage and records the results in the handheld device.
- (4) Uses the moisture meter to measure for subsurface moisture on any wall, floor, ceiling, or component that measured wet during the initial mold inspection and records the results in the handheld device.

NYCHA STANDARD PROCEDURE MANUAL

- (5) If mold, water damage, or moisture (a wet measurement) is found during the quality assurance mold inspection:
 - (a) Fails the quality assurance mold inspection and closes the quality assurance mold inspection work order. Maximo automatically generates a new related mold work order (mold re-inspection).
 - (b) Immediately performs a full mold inspection following the steps in Section VIII.C.1., Performing the Initial Mold Inspection, above.
 - (c) If no mold, water damage, or moisture (wet measurement) is found, continues with the quality assurance mold inspection.
- (6) If an air flow measurement was taken during the initial mold inspection, uses an anemometer to take an air flow measurement in cubic feet per minute of the exhaust vent. See Appendix D – Instructions for the New Version of the Testo App for instructions.
- (7) Confirms that all work (child work orders) to remediate mold and correct root causes and related conditions was completed satisfactorily.
- (8) Performs a desktop review of the child work orders.
- (9) Reviews the work actuals of the child work orders using the handheld device.
 - (a) Visually inspects all completed work in the area related to the child work orders.
 - (b) If all work was completed satisfactorily, completes the quality assurance mold inspection by taking multiple close-up photos from different angles and at least one photo of the larger area of the mold inspection area(s) free of mold, water damage, and/or moisture and uploading the photo(s) into Maximo. See Appendix C – Sample Photos of Mold Conditions.
 - (c) If any work was not completed satisfactorily:
 - i. Immediately creates a child work order in Maximo.
 - ii. Takes and uploads multiple close-up photos from different angles and at least one photo of the larger area of the unsatisfactory work into Maximo if the work is visible in the area. See Appendix C – Sample Photos of Mold Conditions.
 - iii. Closes the existing quality assurance mold inspection work order.

NYCHA STANDARD PROCEDURE MANUAL

- iv. Follows up with supervisor or the staff person(s) who performed the work to report the unsatisfactory work and ensure that the work is completed.

3. Performance Reporting

The Office of Mold Assessment and Remediation assigns:

a. Staff to review reports to identify developments with:

- (1) Times to complete parent mold work orders that are higher than NYCHA and/or borough average.
- (2) Rates of unfounded mold work orders that are higher than NYCHA and/or borough average.
- (3) Rates for recurrent mold work orders that are higher than NYCHA and/or borough average.
- (4) Quality assurance failure rates that are higher than NYCHA and/or borough average.

b. Supervisory staff trained in mold inspections to:

- (1) Visit developments and inspect randomly selected apartments with high rates of unfounded or recurring (as applicable) mold work orders.
- (2) Report findings on the underlying issue, such as a building system and/or mold inspection and remediation process issue.
- (3) Provide follow up recommendations to the neighborhood administrator.
 - (a) To address building system issues, the supervisory staff may, for example, recommend additional repairs.
 - i. The neighborhood administrator addresses issues by requesting additional training, reviewing key accountabilities, or providing progressive discipline to the property maintenance supervisor and/or property manager.
 - (b) For comprehensive building systems issues, such as a roof, roof tank, or entire line, the supervisory staff may, for example, recommend additional repairs or escalation to the Asset and Capital Management Department.

c. Staff trained in scheduling mold work orders to:

- (1) Provide follow up recommendations to the skilled trades deputy director, neighborhood administrator, or director of technical resources.

NYCHA STANDARD PROCEDURE MANUAL

- (a) For building system issues, the Office of Mold Assessment & Remediation staff may recommend additional repairs and perform repairs in selected instances.
- (b) For processing issues, recommendations could include providing additional training, reviewing key accountabilities, and/or providing progressive discipline.
 - i. The Property Management Department skilled trades deputy director addresses issues with the borough planner, skilled trades administrators, and skilled trades supervisors.
 - ii. The director of technical resources addresses issues with Technical Resources skilled trades administrators and supervisors.

I. Resident Engagement and Communication

1. The inspector calls the resident before arriving at the apartment on the day of the mold inspection to remind them of the appointment.
2. After completing an initial mold inspection work order, the inspector:
 - a. Discusses the inspection findings with the resident and the root cause(s) identified as the source of mold.
 - b. If mold is identified, shares with the resident general recommendations to prevent the condition from reoccurring and gives the resident NYCHA Form 060.303, *Controlling Mold in Your Apartment*, and NYCHA Form 060.845, *Mold Inspection Receipt*.
 - c. Advises the resident to avoid anything that can cause or contribute to the mold condition and if repair is required, which work orders were generated, or that no repair is required, and why.
 - d. Discusses with the resident the next steps that NYCHA will take to address the mold and the root cause(s). Maintenance workers complete simple repairs (completed right away) and Skilled Trades employees complete complex repairs (contact the neighborhood planner regarding timelines to complete complex repairs).
 - e. If the resident disagrees with the initial mold inspection findings or has additional concerns or complaints about the inspection and associated repair(s), informs the resident that they may contact NYCHA's Compliance Department or the independent court-appointed Ombudspersons Call Center as documented on NYCHA Form 060.845, *Mold Inspection Receipt*.
 - f. Informs the resident that for inspections that find mold, they will be mailed NYCHA Form 060.846, *Mold Inspection Review*, which includes:

NYCHA STANDARD PROCEDURE MANUAL

- (1) Findings from the initial mold inspection and identified root cause(s).
- (2) The list of (child) repair work orders created to remediate the root cause(s) – including the work order number, description, and craft.
- (3) The contact information of the neighborhood planner or Property Management Office to schedule work.
- (4) The contact information of NYCHA's Compliance Department and Ombudspersons Call Center if the resident has any concerns or complaints regarding completed mold inspection and associated repairs.

NOTE:	This form is autogenerated by Maximo and mailed by the General Services Department.
--------------	---

3. Skilled Trades or other maintenance staff call the resident before arriving at the apartment on the day of work to remediate the mold to remind them of the appointment.

NOTE:	If required to effectively communicate with the resident, the inspector must request language assistance services. See NYCHA Standard Procedure 007:09:1, <i>Language Assistance Services</i> .
--------------	---

IX. OUTPUTS, REPORTS, AND RECORDKEEPING

A. Outputs

1. Mold in NYCHA apartments is remediated and the root causes are identified and corrected within the established timeframes.
2. Mold recurrence (same apartment/same room) is reduced.
3. Mold activities are monitored to ensure compliance with this Standard Procedure.
4. All required documents are provided to residents and required parties.

B. Reports

1. The scorecard updates twice a week on Mondays and Wednesdays. It is required that vice presidents, operations administrators, skilled trades deputy directors, skilled trades administrators, borough planners, neighborhood administrators, neighborhood planners, property managers, property maintenance supervisors, and assistant property maintenance supervisors review the scorecard at least once per week.
2. To access the scorecard, visit the NYCHA Connect Homepage and navigate to the Data Warehouse located in Apps. From there, click on "Operations" and select "Mold and Leak Scorecard." The scorecard also may be accessed through the direct link: NYCHA: Mold and Leak Scorecard - Tableau Cloud. Multi-Factor Authentication (MFA) setup is

NYCHA STANDARD PROCEDURE MANUAL

required to log in successfully to the scorecard. If a new staff member with a title listed directly above in B.1. requires access to the scorecard, access may be requested by contacting Office of Mold Assessment and Remediation by e-mail at mold.busters@nycha.nyc.gov.

C. Recordkeeping

The Information Technology Business Solutions Technology Department Maximo Unit retains electronically created and stored completed work orders for at least seven years.

X. TRAINING REQUIREMENTS

The Learning and Development Unit, in conjunction with Operations departments, provides or contracts to provide Mold Busters training, as applicable.

Mold Busters training is required for staff that perform mold inspections and remediations. The training is provided after an employee starts working at NYCHA, and it is required that previously certified inspectors participate in a mold inspection refresher training once every two years thereafter. Only employees who have received the required inspector training are permitted to perform mold inspections. Supervisors must not assign staff to perform mold inspections if the staff member has not received this training. The goal of training is to provide attendees with knowledge and practical understanding of procedures and practices for mold inspection, building sciences, and mold remediation.

A. Mold Inspections

Attendees: Property Maintenance Supervisors, Assistant Property Maintenance Supervisors, Property Managers, Neighborhood Administrators, Maintenance Workers, Neighborhood Planners, Borough Planners.

Day 1 includes detail on background, mold health effects, NYCHA requirements, and mandated inspection and remediation timelines as well as an introduction to this Standard Procedure. Attendees will also learn about and work with inspection instruments such as the hygrometer, anemometer, and moisture meter that are used during inspections.

Day 2 is dedicated to practical skills associated with inspections. Attendees will begin working with "dummy" mold inspection parent work orders using iWM on training handhelds. It includes an interactive virtual reality (VR) simulation in which users will participate in a mold inspection. Attendees will become familiar with mold remediation practices, PPE, and safety considerations that are an important "next step" once the mold inspection is complete.

Day 3 focuses on quality assurance and re-inspections performed after root cause repairs and/or mold remediation is complete. Students will begin working on dummy quality assurance & re-inspection work orders, with improved understanding of the entire mold inspection, remediation, and the quality assurance process. Training concludes with case studies, a review, and a knowledge assessment designed to demonstrate the knowledge and skill obtained in this training.

NYCHA STANDARD PROCEDURE MANUAL

Course Materials:

- Course Manual & Handouts
- Dummy Phone, Work Orders, and Scenarios
- Mold Inspection Instruments (e.g., hygrometer, anemometer, moisture meter, borescope)

B. Mold Building Sciences

Attendees: Property Maintenance Supervisors, Assistant Property Maintenance Supervisors, Property Managers, Neighborhood Administrators, Maintenance Workers.

Day 1 includes background, mold health effects, NYCHA requirements, and mandated inspection and remediation timelines as well as an introduction to this Standard Procedure. Staff will learn the fundamentals of mold remediation in NYCHA facilities and other project related environmental, health, and safety considerations that may impact residents and staff during root cause repair and remediation. This includes an introduction to remediation equipment, materials, and PPE.

Day 2 is dedicated to practical skills associated with remediation. Attendees will learn and undertake "hands-on" remediation techniques, including work area preparation, wall breaks, vent cleaning, pipe re-insulation, and other root cause repair and remediation techniques. It includes an interactive virtual reality (VR) simulation in which users will observe and participate in mold remediation. Training concludes with a review and a knowledge assessment designed to demonstrate the knowledge and skill obtained in this training.

Course Materials:

- Course Manual & Handouts
- Mold Inspection Equipment (Borescope)
- Work Area Containment, Control & Cleaning Materials & Supplies
- Root Cause & Remediation Equipment (such as Insulation, HEPA Vacuums, Hand Tools)

C. Mold Remediation

Attendees: Skilled Trades, Caretaker X and P, Lead Abatement Workers

This full day presentation includes background, mold health effects, NYCHA requirements, mandated inspection and remediation timelines as well as an introduction to this Standard Procedure. Attendees will learn the fundamentals of mold remediation in NYCHA facilities and other project-related environmental, health and safety considerations that may impact

Page 53
Index No. 040:14:1
Revised 6/11/2024

NYCHA STANDARD PROCEDURE MANUAL

residents and staff during root cause repair and remediation. This includes an introduction to remediation equipment, materials, and PPE. Attendees will also learn and undertake "hands-on" remediation techniques, including work area preparation, wall breaks, vent cleaning, pipe re-insulation, and other root cause repair and remediation techniques. Training concludes with a review and a knowledge assessment designed to demonstrate to attendees the knowledge and skill obtained in this training.

Course Materials:

- Course Manual & Handouts
- Work Area Containment, Control & Cleaning Materials & Supplies
- Root Cause & Remediation Equipment (ex. Insulation, HEPA Vacuums, Hand Tools)

D. Inspector Refresher

Attendees: Property Maintenance Supervisors, Assistant Property Maintenance Supervisors, Housing Managers, Neighborhood Administrators, Maintenance Workers.

A one-half day refresher training program provided every two years to NYCHA staff who have completed inspector training. The refresher will review and update attendees with important elements of the initial training and current inspection practices. The course will include practical exercises using the iWM handheld app to complete dummy work orders and hands-on demonstrations of proper use of mold inspection instruments.

Course Materials:

- Course Manual & Handouts
- Dummy Phones, Work Orders, and Scenarios
- Mold Inspection Instruments (e.g., hygrometer, anemometer, moisture meter, borescope)

E. Mold All Trades Refresher

Attendees: Supervisors, Assistant Supervisors, Property Managers, Neighborhood Administrators, Maintenance Workers, Skilled Trades, Caretaker X and P.

A one-half day refresher training program provided every two years to NYCHA staff who have completed inspector, building sciences, and/or remediation methods training. The refresher will review and update attendees with important elements of the initial training and current remediation procedures and includes hands-on/demonstration of remediation practices. It offers the opportunity for all those who have completed NYCHA mold training (managers, supervisors, and trades) to interact in the same session and develop a common understanding of the mold program goals and outputs.

NYCHA STANDARD PROCEDURE MANUAL

Course Materials:

- Course Manual & Handouts
- Mold Inspection Equipment (Borescope)
- Work Area Containment, Control & Cleaning Materials, and Supplies
- Root Cause & Remediation Equipment (e.g., Insulation, HEPA Vacuums, Hand Tools)

F. Certification Requirements

Vendors hired to perform mold assessment or remediation on NYCHA properties must be licensed as mold assessment and remediation contractors by the New York State Department of Labor. Only licensed mold assessor and licensed mold remediation can perform the work.

XI. PERFORMANCE METRICS

- A. Average number of calendar days to complete simple and complex repairs and close mold child work orders.
- B. Average number of calendar days to complete initial inspections.
- C. Percentage of mold work orders for recurring mold.
- D. Percentage of failed quality assurance mold inspections.

XII. NON-COMPLIANCE

- A. NYCHA staff involved in working with mold and mildew control in NYCHA developments are required to comply with this Standard Procedure.
- B. Departments are required to take corrective action to bring NYCHA into compliance.
- C. If unsatisfactory work or non-compliance is identified, supervisory staff must take one or more of the following actions:
 - 1. Identify areas for follow up training for the employee(s) and ensure training is scheduled and provided.
 - 2. Reinforce with the employee(s) the job expectations, accountabilities, and the progressive discipline process.

NYCHA STANDARD PROCEDURE MANUAL

- D. Failure to comply with the requirements of this Standard Procedure may result in disciplinary actions as per the NYCHA Human Resources Manual.
- E. For work performed by vendors, supervisors must certify the completion of work performed to industry standards. If vendor work is not satisfactorily completed, supervisors must request that the vendor complete the work to NYCHA's satisfaction by a specified date. If the vendor has not corrected the work by the specified date, the supervisor must follow the contract guidance. Copies of all correspondence with the vendor must be filed in the contract folder.

XIII. FORMS

- A. NYCHA Form 042.727, *48 Hour Notice for Health & Safety Repairs*
- B. NYCHA Form 060.303, *Controlling Mold in Your Apartment*
- C. NYCHA Form 060.845, *Mold Inspection Receipt*
- D. NYCHA Form 060.846, *Mold Inspection Review*
- E. NYCHA Form 040.126, *Personal Property Damage*
- F. NYCHA Form 088.168, *Notice of Scheduled Appointment for Repairs*

XIV. WORKFLOW

This section intentionally left blank.

NYCHA STANDARD PROCEDURE MANUAL

XV. REVIEW/REVISION HISTORY PAGE

Review/ Revision	Review/ Revision Date	Sections Amended
1.	Not applicable -- new Standard Procedure	The Standard Procedure was posted as a draft on the Forms & Reference Library on May 19, 2014. NYCHA staff used the posted draft as agency policy beginning on the effective date of May 21, 2014.
2.	6/3/2015	Banner
3.	6/3/2015	VI, Assessment of Mold/Mildew: The First Staff Visit
4.	12/19/18	Procedure updated and organized into current Standard Procedure format.
5.	12/19/18	Section I, Purpose
6.	12/19/18	Section II, Policy
7.	12/19/18	Section III, Applicability
8.	12/19/18	Added Section IV, Introduction to Mold and Moisture Control
9.	12/19/18	Added Section V, Definitions
10.	12/19/18	Section VI, Review Cycle
11.	12/19/18	Added Section VII, Responsibilities
12.	12/19/18	Added Section VIII, Procedure
13.	12/19/18	Added Section IX, Outputs, Reports, and Recordkeeping
14.	12/19/18	Added Section X, Training Requirements
15.	12/19/18	Added Section XI, Performance Metrics
16.	12/19/18	Added Section XII, Non-Compliance
17.	12/19/18	Section XIII, Forms
18.	12/19/18	Added Section XIV, Workflow
19.	12/19/18	Added Section XV, Review/Revision History Page
20.	12/19/18	Added Section XVI, Appendices
21.	12/19/18	Removed previous appendices A-G
22.	12/19/18	Added Appendix A, Remediation Methods
23.	12/19/18	Added Appendix B, HA Numbers for Mold Related Tools and Supplies
24.	12/19/18	Added Appendix C, Instructions for Using the Anemometer
25.	1/3/19	Section VIII.C, Remediating Mold and Related Conditions
26.	1/3/19	Section VIII.D, Correcting Root Causes
27.	10/17/19	Section VIII.G, Procedure
28.	2/26/20	Banner
29.	2/26/20	Section II, Policy
30.	2/26/20	Section III, Applicability
31.	2/26/20	Section IV, Introduction to Mold and Moisture Control
32.	2/26/20	Section V, Definitions
33.	2/26/20	Section VI, Review Cycle
34.	2/26/20	Section VII, Responsibilities
35.	2/26/20	Section VIII, Procedure, Subsections A-H

NYCHA STANDARD PROCEDURE MANUAL

36.	2/26/20	Section IX, Outputs, Reports, and Recordkeeping
37.	2/26/20	Section X, Training Requirements
38.	2/26/20	Section XII, Non-Compliance
39.	2/26/20	Appendix A, Remediation Methods
40.	2/26/20	Appendix B, HA Numbers for Mold Related Tools and Supplies
41.	2/26/20	Appendix C, Instructions for Using the Anemometer
42.	6/11/2024	Banner
43.	6/11/2024	Section V., Definitions, including adding Baez consent decree, child work order, mildew, mold and leak performance scorecard ("scorecard"), mold service level agreement, parent work order, public space, recurrence, unfounded, and vendor
44.	6/11/2024	Section VII., Responsibilities, including adding Compliance Department, Environmental Health and Safety Department, Ombudsperson Call Center, Office of Mold Assessment and Remediation Mold Response Unit, and employees who manage vendors that perform mold remediation
45.	6/11/2024	Section VIII.A., Creating and Scheduling Mold Service Requests
46.	6/11/2024	Section VIII.B., Inspecting Mold Conditions in Apartments, including adding a chart for root causes of mold or mildew
47.	6/11/2024	Added Section VIII.C., Inspecting Mold Conditions in Public Spaces and Other Non-Residential Spaces
48.	6/11/2024	Section VIII.D., Remediating Mold and Related Conditions – Apartments, Public Spaces, and Other Non-Residential Spaces, including adding a chart for the titles that perform remediation based on the amount of mold and a list of public spaces and other non-residential spaces
49.	6/11/2024	Section VIII.E., Correcting Root Causes
50.	6/11/2024	Section VIII.F., Time Frames to Respond to Mold and Related Issues
51.	6/11/2024	Section VIII.H., Quality Assurance, including adding the quality assurance mold inspection process for public spaces and other non-residential spaces
52.	6/11/2024	Added Section VIII.I., Resident Engagement and Communication
53.	6/11/2024	Section IX., Outputs, Reports, and Recordkeeping
54.	6/11/2024	Section X., Training Requirements
55.	6/11/2024	Section XI., Performance Metrics
56.	6/11/2024	Section XII., Non-Compliance
57.	6/11/2024	Section XIII., Forms
58.	6/11/2024	Appendix A – Remediation Methods
59.	6/11/2024	Appendix B – HA Numbers for Mold Related Tools and Supplies
60.	6/11/2024	Added Appendix C – Sample Photos of Mold Conditions
61.	6/11/2024	Added Appendix D – Instructions for the New Version of the Testo App
62.	6/11/2024	Added Appendix E – Instructions for Using a Moisture Meter
63.	6/11/2024	Added Appendix F – Creating a Mold Inspection in Apartments on the Handheld

NYCHA STANDARD PROCEDURE MANUAL

64.	6/11/2024	Added Appendix G – Creating a Mold Inspection in Public Spaces and Other Non-Residential Spaces on the Handheld
65.	6/11/2024	Added Appendix H – Scorecard Factors

NYCHA STANDARD PROCEDURE MANUAL

XVI. APPENDICES

A. Appendix A – Remediation Methods

1. Ceiling: Painted Concrete (Leak or Condensation; All Rooms)

- a. HEPA vacuum and clean surfaces displaying water damage, mold growth, and/or that measure wet with a NYCHA-approved disinfectant or cleaning solution. See Appendix B – HA Numbers for Mold Related Tools and Supplies, for a list of HA numbers for ordering supplies.
- b. Wet-scrape loose or damaged paint from surfaces to remove the affected paint and top-coated plaster/skim-coating to which the paint is adhered. Continue wet scraping to a point of 12 inches beyond any visible water damage, mold growth, and/or areas that measure wet.
- c. Apply NYCHA-approved mold resistant coating.
- d. Repaint with mold resistant paint.

NOTE:	When a ceiling is textured and the material may be disturbed, the Property Maintenance Office must contact the Asbestos Department for guidance.
--------------	--

2. Ceiling: Sheetrock with Steel Framing (Leak or Condensation; All Rooms)

- a. Remove and dispose of sheetrock displaying visible water damage, mold growth, and/or that measures wet. Continue removal to a point of at least six inches beyond any visible water damage or mold growth on the front or back sides of the sheetrock and/or areas that measure wet or up to the next available framing member. In areas where significant water damage, mold growth, or moisture is present on sheetrock, a HEPA vacuum should be used at the point of dust generation during the sheetrock removal work.

NOTE:	<ul style="list-style-type: none">• Moldy sheetrock must be placed inside six-mil plastic trash bags.• After being placed in the trash bag, the bag must be tied with an airtight gooseneck seal:<ul style="list-style-type: none">○ Gather and twist the end eight to ten inches down.○ Make a loop with the twisted end.○ Seal tightly with duct tape.• Dispose the trash bag with sheetrock in the regular garbage.
--------------	--

- b. Replace sheetrock with fiberglass-faced gypsum board. For seam taping, use fiberglass mesh tape in place of paper tape.
- c. Apply NYCHA-approved mold resistant compound. See Appendix B – HA Numbers for Mold Related Tools and Supplies, for a list of HA numbers for ordering supplies.

NYCHA STANDARD PROCEDURE MANUAL

- d. Repaint with mold resistant paint.

NOTE:	When a ceiling is textured and the material may be disturbed, the Property Maintenance Office must contact the Asbestos Department for guidance.
--------------	--

3. Ceiling: Sheetrock with Wood Framing (Leak or Condensation; All Rooms)

- a. Remove and dispose of sheetrock displaying visible water damage, mold growth, and/or that measures wet. Continue removal to a point of at least six inches beyond any visible water damage or mold growth on the front or back sides of the sheetrock and/or areas that measure wet or up to the next available framing member. In areas where significant water damage, mold growth, or moisture is present on sheetrock, a HEPA vacuum should be used at the point of dust generation during the sheetrock removal work.
- b. HEPA vacuum and clean with a NYCHA-approved disinfectant or cleaning solution any wood framing components displaying minor levels of water damage and/or mold growth. See Appendix B – HA Numbers for Mold Related Tools and Supplies, for a list of HA numbers for ordering supplies.
- c. Paint any wood framing components displaying dried water damage and/or minor levels of mold growth conditions with fungicidal/fungistatic coating, only after all mold is remediated.
- d. Remove and replace wood framing displaying significant mold growth.
- e. Replace sheetrock with fiberglass-faced gypsum board. For seam taping, use mesh fiberglass tape in place of paper tape.
- f. Repaint with mold resistant paint.

NOTE:	When a ceiling is textured and the material may be disturbed, the Property Maintenance Office must contact the Asbestos Department for guidance.
--------------	--

4. Walls: Painted Plaster (Leak or Condensation; All Rooms)

- a. HEPA vacuum and clean surfaces displaying water damage, mold growth, and/or that measure wet with a NYCHA-approved disinfectant or cleaning solution. See Appendix B – HA Numbers for Mold Related Tools and Supplies, for a list of HA numbers for ordering supplies.
- b. Wet-scrape to remove the affected paint and top-coated plaster or skim-coating to which the paint is adhered. Continue wet-scraping to a point of at least 12 inches beyond any visible water damage, mold growth, and/or areas that measure wet.

NYCHA STANDARD PROCEDURE MANUAL

- c. Apply NYCHA-approved mold resistant coating.
- d. Repaint with mold resistant paint.

5. Walls: Sheetrock with Steel Framing (Leak or Condensation; All Rooms)

- a. Remove and dispose of sheetrock displaying visible water damage, mold growth, and/or that measure wet. Continue removal to a point of at least six inches beyond any visible water damage or mold growth on the front or back sides of the sheetrock and/or areas that measure wet or up to the next available framing member. In areas where significant water damage, mold growth, or moisture is present on sheetrock, a HEPA vacuum should be used at the point of dust generation during the sheetrock removal work.
- b. Replace sheetrock with fiberglass-faced gypsum board. For seam taping, use fiberglass mesh tape in place of paper tape.
- c. Apply NYCHA-approved mold resistant compound. See Appendix B – HA Numbers for Mold Related Tools and Supplies, for a list of HA numbers for ordering supplies.
- d. Repaint with mold resistant paint.

6. Walls: Sheetrock with Wood Framing (Leak or Condensation; All Rooms)

- a. Remove and dispose of sheetrock displaying visible water damage, excessive mold growth, and/or that measures wet. Continue removal to a point of at least six inches beyond any visible water damage or mold growth on the front or back sides of the sheetrock and/or areas that measure wet or up to the next available framing member. In areas where significant water damage, mold growth, or moisture is present on sheetrock, a HEPA vacuum should be used at the point of dust generation during the sheetrock removal work.
- b. HEPA vacuum and clean any wood framing components displaying minor levels of water damage and/or mold growth with a NYCHA-approved disinfectant or cleaning solution. See Appendix B – HA Numbers for Mold Related Tools and Supplies, for a list of HA numbers for ordering supplies.
- c. Paint any wood framing components displaying water damage and/or minor levels of mold growth conditions with fungicidal/fungistatic coating after remediation is completed.
- d. Remove and replace wood framing displaying significant mold growth.
- e. Replace sheetrock with fiberglass-faced gypsum board. For seam taping, use mesh fiberglass tape in place of paper tape.
- f. Apply NYCHA-approved mold resistant compound.

NYCHA STANDARD PROCEDURE MANUAL

- g. Repaint with mold-resistant primer and paint.

7. Floors: Finished Wood Floors (Leak or Condensation; All Rooms)

- a. Remove and dispose of finished wood floorboards displaying significant water damage (buckling) and/or that measure wet. Continue removal to a point of 12 inches beyond any visible mold growth on the top and/or bottom sides of finished wood floorboards, plywood sub-flooring, and/or sleepers or to the perimeter of the room.
- b. Examine joist elements to assess the extent of mold growth. If a joist shows signs of mold and/or water damage, consider replacing the entire joist or, if feasible, performing joist sistering. Use a HEPA vacuum, clean thoroughly with a NYCHA-approved disinfectant or cleaning solution, apply NYCHA-approved mold resistant coating, and repaint with mold resistant paint.
- c. If wet, water-damage, and/or mold growth conditions reach the perimeter of a room, evaluate flooring in the adjacent room to determine if additional removal work is necessary.
- d. Replace flooring.

8. Floors: Ceramic Floors (Leak or Condensation; All Rooms)

- a. Clean surfaces thoroughly using a NYCHA-approved disinfectant or cleaning solution. See Appendix B – HA Numbers for Mold Related Tools and Supplies, for a list of HA numbers for ordering supplies.
- b. Inspect the extent of the damage to the ceramic tiles, replace tiles in areas that have missing tiles, and reenforce loose tiles.

9. Floors: Vinyl Floor Tiles (Leak or Condensation; All Rooms)

- a. Remove and dispose of water-damaged vinyl floor tiles or tiles measuring wet.
- b. HEPA vacuum underlying concrete slab and clean using a NYCHA-approved disinfectant or cleaning solution. See Appendix B – HA Numbers for Mold Related Tools and Supplies, for a list of HA numbers for ordering supplies.
- c. Replace floor tiles.

10. Kitchen Cabinetry and Bathroom Vanities (Significant Mold)

- a. Remove and dispose of cabinetry.
- b. Replace cabinetry.

NYCHA STANDARD PROCEDURE MANUAL

11. Bathtub and Shower Grout or Caulking

- a. Where grout or caulking displays heavy and widespread levels of mold growth, dig out existing grout or caulking and replace with a NYCHA-approved mold resistant product.

12. Minor Mold Growth (On Painted Surfaces, Shower Grout, Cabinets, etc.)

- a. Clean surfaces thoroughly using a NYCHA-approved disinfectant or cleaning solution. See Appendix B – HA Numbers for Mold Related Tools and Supplies, for a list of HA numbers for ordering supplies.

NYCHA STANDARD PROCEDURE MANUAL

B. Appendix B – HA Numbers for Mold Related Tools and Supplies

1. Supplies

HA #	Material Item	Material Item Specification (if applicable)	Application
1404922227	Foster 40-50 Paint	5 Gallon Container	Used as per remediation method
1404934829	Zinsser Mold Resistant Paint	Paint, Zinsser Perma white semi-gloss # t24	If there is a desire to add a finishing touch with NYCHA standard color,
1404934830	Zinsser Mold Resistant Paint	Paint, Zinsser Perma white semi-gloss # 18c	If there is a desire to add a finishing touch with NYCHA standard color,
1214922226	Plas-tec	4 X 8 Sheet	Provide waterproof barrier behind toilet
1219924836	Heavy Duty Adhesive	Multipurpose Type for Various Construction Projects, Liquid Nails #	Adhesive for plastic panel
1220991245	White Tub & Tile Sealant Caulking Silicone	10.1 oz Cartridge Packed 24/box G.E. SCS1702	Sealing base of toilets and shower walls
1216984470	Silicone Caulking Sealant and Adhesive, Clear Color		Sealing base of toilets and shower walls
0304920052	Micro Filter	Micro Filter, 10 Quantity Replacement Filters	Used with backpack vacuum
0806938344	Microbiowash		Detergent
080657583	ShockWave		Detergent
140492228	Fiberlock IAG 6000	5 Gallon Container	Used as per remediation method
806932259	Enviro Care Neutral Disinfectant surface disinfectant		Detergent
1210945694	Georgia-Pacific DensArmor Plus Mold & Moisture Resistant Interior Panel (mold SP)		Mold resistant sheetrock
1225963003	USG Sheetrock Brand Glass Mat Mold Tough (regular)		Mold resistant sheetrock

NYCHA STANDARD PROCEDURE MANUAL

HA #	Material Item	Material Item Specification (if applicable)	Application
1225963002	Gold Bond eXP Interior Extreme Gypsum Panel		Mold resistant sheetrock
1404924256	FibaTape Mold-X 10	1 7/8 inch by 300 ft roll	Mold resistant tape used for seam taping when sheetrock is replaced with fiberglass-faced gypsum board.
1212919100	USG Imperial Natural Veneer Plaster Basecoat	50-pound bag	Mold resistant plaster basecoat used for sealing seams when sheetrock is replaced with fiberglass-faced gypsum board.
1212919101	USG Diamond Veneer Plaster Finish 50 lb.	50-pound bag	Mold resistant plaster finish used for sealing seams when sheetrock is replaced with fiberglass-faced gypsum board.
1207923801	Owens Corning ASJ Max Fiberglass Pipe Insulation 0.5" diameter		Used for pipe insulation.
1207923804	Owens Corning ASJ Max Fiberglass Pipe Insulation 0.75" diameter (3/4)		Used for pipe insulation.
1207923807	Owens Corning ASJ Max Fiberglass Pipe Insulation 1" diameter		Used for pipe insulation.
1207923810	Owens Corning ASJ Max Fiberglass Pipe Insulation 1.5" diameter		Used for pipe insulation.
1207923813	Owens Corning ASJ Max Fiberglass Pipe Insulation 2" diameter		Used for pipe insulation.
1207923816	Owens Corning ASJ Max Fiberglass Pipe Insulation 2.5" Diameter		Used for pipe insulation.

NYCHA STANDARD PROCEDURE MANUAL

HA #	Material Item	Material Item Specification (if applicable)	Application
1207993960	Insulation, Fiberglass Copper Pipe Insulation, 5/8" Pipe Size With 1" Pipe Thickness, Owen Corning/Manville Part #0110006		Used for pipe insulation.
1207930275	Insulation, Fiberglass Copper Pipe Insulation, 1-1/4" Pipe Size With 1" Pipe Thickness, Owen Corning/Manville Part #0110012		Used for pipe insulation.
1207993962	Insulation, Fiberglass Copper Pipe Insulation, 2-1/8" Pipe Size With 1" Pipe Thickness, Owen Corning/Manville Part #0110021		Used for pipe insulation.
1207993963	Insulation, Fiberglass Copper Pipe Insulation, 2-5/8" Pipe Size With 1" Pipe Thickness, Owen Corning/Manville Part #0110026		Used for pipe insulation.
1207930272	Insulation PVC Elbow, PVC 90° Degree PVC Elbow Pipe Fitting Cover, 1" Thickness For 1/2" Pipe (Size 7); Proto/JM SKU #300790		Used for pipe insulation.
1207930274	Insulation PVC Elbow, PVC 90° Degree PVC Elbow Pipe Fitting Cover, 1" Thickness For 1" Pipe (Size 9); Proto/JM SKU #300990		Used for pipe insulation.

NYCHA STANDARD PROCEDURE MANUAL

HA #	Material Item	Material Item Specification (if applicable)	Application
1207930275	Insulation PVC Elbow, PVC 90° Degree PVC Elbow Pipe Fitting Cover, 1" Thickness For 1-1/2" Pipe (Size 10); Proto/JM SKU #301090		Used for pipe insulation.
1207930276	Insulation PVC Elbow, PVC 90° Degree PVC Elbow Pipe Fitting Cover, 1" Thickness For 2" Pipe (Size 11); Proto/JM SKU #301190		Used for pipe insulation.
1207930277	Insulation PVC Elbow, PVC 90° Degree PVC Elbow Pipe Fitting Cover, 1" Thickness For 2-1/2" Pipe (Size 12); Proto/JM SKU #301290		Used for pipe insulation.
1207930280	Insulation PVC Tee/Valve Cover, Tee PVC Fitting, 1" Thickness For 1/2" Pipe (Size 7); Proto/JM SKU #3007TV		Used for pipe insulation.
1207930281	Insulation PVC Tee/Valve Cover, Tee PVC Fitting, 1" Thickness For 1" Pipe (Size 9); Proto/JM SKU #3009TV		Used for pipe insulation.
1207930282	Insulation PVC Tee/Valve Cover, Tee PVC Fitting, 1" Thickness For 1-1/2" Pipe (Size 10); Proto/JM SKU #3010TV		Used for pipe insulation.

NYCHA STANDARD PROCEDURE MANUAL

HA #	Material Item	Material Item Specification (if applicable)	Application
1207930283	Insulation PVC Tee/Valve Cover, Tee PVC Fitting, 1" Thickness For 2" Pipe (Size 11); Proto/JM SKU #3011TV		Used for pipe insulation.
1207930284	Insulation PVC Tee/Valve Cover, Tee PVC Fitting, 1" Thickness For 2-1/2" Pipe (Size 12); Proto/JM SKU #3012TV		Used for pipe insulation.
1216995800	Childers CP-11 Gallon		Waterproofing, adhesive, and sealant material.

2. Tools

HA #	Material Item	Material Item Specification	Application
2016125015	Putty Knife	1-1/4" Stiff Blade	Spread adhesive for plastic panel
2016125020	Putty Knife	1-1/2", Flex Professional Type, Stanley #28241	Spread adhesive for plastic panel
2022922432	V-Notched Trowel	Flat Top for Flooring, 9" X 1/8" X 1/16"	Spread adhesive for plastic panel
2022922431	Roller	3" J-Type, Use for Plastic Laminate	Press plastic panel into adhesive and ensure good bond
2022922433	Drywall Type T Square	48" X 2", Aluminum, Anodized Finish, 5-Rivet Construction, 1 mm Graduations	Assist in cutting plastic panel
2022991858	Plexiglass Cutter	Heavy Duty, Fletcher #05-120	Assist in cutting plastic panel
2006924266	Spiral Saw	6 Amp, 120 Volt, Complete Kit with Zip Mate, Circle Cutter Guide & Dust Vault, Rotozip # SS560VSC-31	Assist in cutting plastic panel

NYCHA STANDARD PROCEDURE MANUAL

HA #	Material Item	Material Item Specification	Application
0304920051	HEPA Vacuum Cleaner	1 1/2" Static-Dissipating Vacuum Hose, 50' Extension Cord, Two Intercept Micro Filters, 17" Crevice Tool, 3" Dust Brush w/ Reduce, 5" Upholstery Tool, Xover Floor Tool, 42 to 59" Aluminum Telescoping Wand	Assist in controlling airborne particles
1701920185	Moisture Meter	Rugged construction, large backlit display, pin moisture measurement, non-invasive measurement up to 3/4" - 20mm below the surface	Assist in detecting excessive moisture
1701921776	VAC Smart and Wireless Probe Kit	Thermal Anemometer, Vane Anemometer, Thermo-Hygrometers, and Infrared Thermometer	Assist in measuring air velocity, temperature, relative humidity, wet bulb/dew point, and volume flow
1701920186	Vane Anemometer Wireless Smart Probe	Bluetooth Vane Anemometer, 3 AAA Batteries, Certificate of Calibration	Assist in volume-flow measurements and balancing multi-outlet ventilation systems using several instruments
1701920187	Hygrometer Smart and Wireless Probe	Bluetooth Hygrometer, 3 AAA Batteries, Certificate of Calibration	Assist in measuring humidity and temperature
1701920188	Infrared Thermometer	Bluetooth Infrared Thermometer, 3 AAA Batteries, Certificate of Calibration	Assist in non-contact temperature readings from a distance
2003928503	Seesnake Micro Inspection Camera	Model CA-300 with 3 ft. cable, complete with accessories, Rigid #37888	Record and save still images and videos of problems in hard-to-reach areas
2001560020	Wire Brush	10 1/2 X 1 X 5/8" Carbon Steel Wire Scratch Brush	Scrape mold off walls and ceilings
2012112470	Wire Brush	13 rows, 7 columns, 1 3/8" Hand Brush, wire abrasive type	Scrape mold off walls and ceilings in confined/tight spaces

NYCHA STANDARD PROCEDURE MANUAL

C. Appendix C – Sample Photos of Mold Conditions

Close-up Photo Sample



Larger Area Photo Sample



NYCHA STANDARD PROCEDURE MANUAL

D. Appendix D – Instructions for the New Version of the Testo App

1. Switching On and Off

- a. Open the Testo App on your NYCHA-issued handheld device. After the app is open, turn on the anemometer. Press the large button shown as number 1 in the image below. The LED light should start blinking yellow.



- b. The Testo device should automatically pair with your NYCHA issued handheld device. You will know the anemometer has successfully paired when the LED light turns green. **(NOTE: For best results, do not operate more than one Testo device at a time)**

NYCHA STANDARD PROCEDURE MANUAL

2. Overview of the Operating Controls

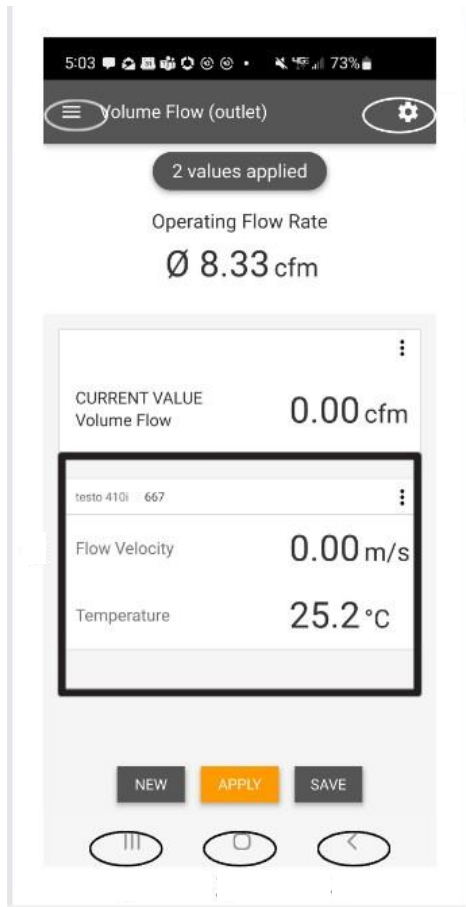

- Choice of applications.
- Display of connected Smart Probes.
- 3-panel switch between the 3 informational views (list, graphic diagram, table).
- Measurement settings. (The menu changes depending on which Smart Probe is connected and which particular device is selected).
- Restarts the measuring value recordings in graph and table format. Allows you to freeze and unfreeze the reading.
- Export the reading.
- Options menu.

NYCHA STANDARD PROCEDURE MANUAL

3. Configuring the New Version of the Testo App to Take an Airflow Reading
 - a. From the Startup Screen, select the list button at the top of the screen.
 - b. Click on Measure.
 - c. On the next selection screen, select **Volume Flow (Outlet)**.
 - (1) Select settings. This selection screen will let you choose the configuration for measurement.

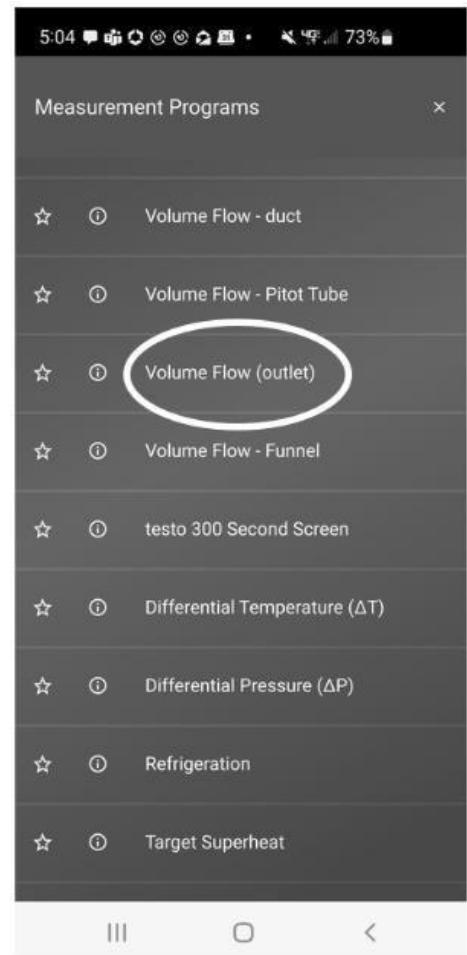
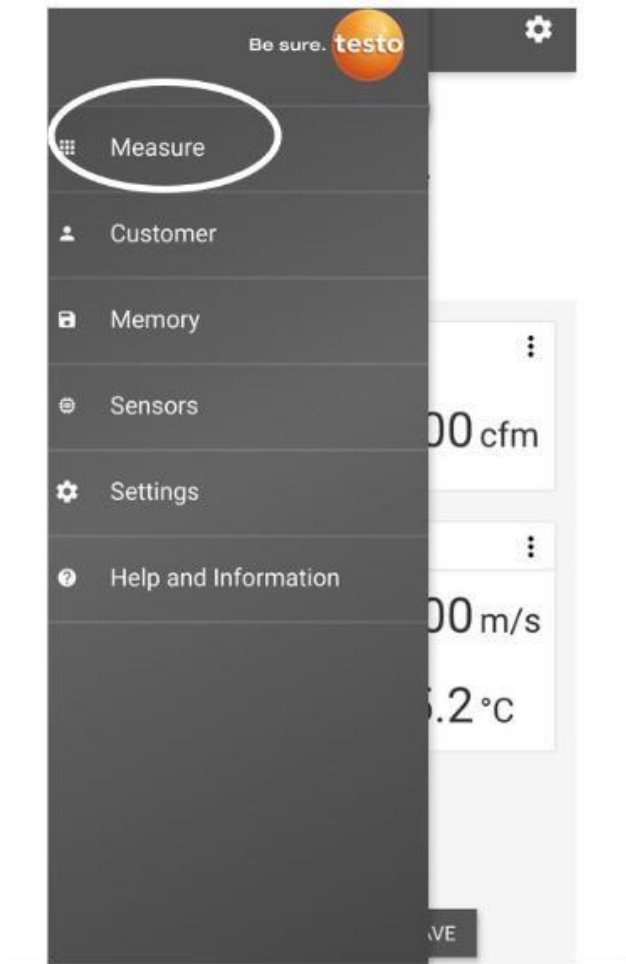

NYCHA STANDARD PROCEDURE MANUAL

- d. On the Configure Measurement screen (pictured below), choose Single measurement. Below that setting, there is a setting for either a rectangular or round air duct measurement.
- (1) Choose the Rectangular measurement.
 - (2) Ensure that the length and width in the app is set to inches. If the unit of measure is not set to inches, use the drop-down triangle symbol to change it.
 - (3) Input the length and width of the air duct being measured.
 - (4) Change the Free Area to **55%**.
 - (5) Ensure the setting for return air is selected.
 - (6) Change the Correction Factor to **1.00**.
 - (7) Hit **Accept Configuration** to save the settings.

5:06 [notification icons] [status icons] 72%

← Volume Flow (outlet)

Measuring Mode
Multi-point

Import measuring site properties
Select measuring site properties

Input Geometry
Rectangular

Air Type
Return Air

Height
6.0 in

Width
9.0 in

Correction Factor
1.00

Free Area
55 %

ACCEPT CONFIGURATION

NYCHA STANDARD PROCEDURE MANUAL

4. On the following screen, adjust the units to the following:
 - a. Click on the 3 dots and select **Edit View**.
 - b. Change unit of measure to **Cubic Feet per Minute (CFM)**.
 - c. Change temperature units to **Fahrenheit (°F)**.
 - d. Change unit of measure to **Feet Per Minute (FPM)**.
 - e. Select **APPLY** at the bottom of the screen to save your unit selections.

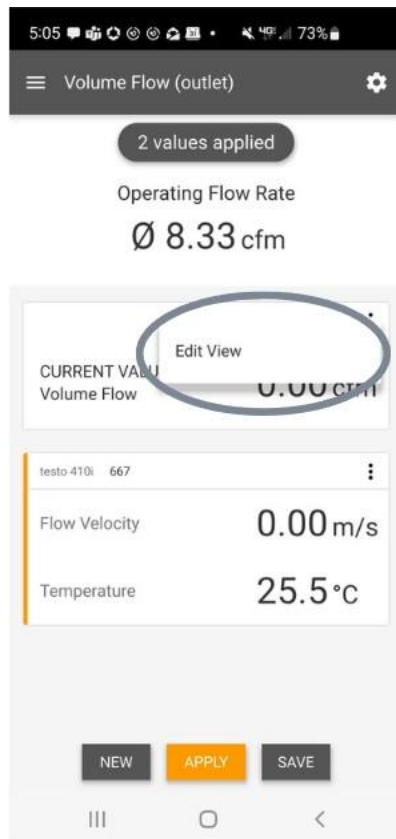

NYCHA STANDARD PROCEDURE MANUAL

5. Taking a Flow Measurement

- a. Place the anemometer so it is flush with the face of the air duct grill.
- b. The results will be displayed on the Volume Flow (outlet) screen (pictured below).
- c. To freeze a flow measurement, press the Apply and Save buttons at the same time on the bottom of the screen.

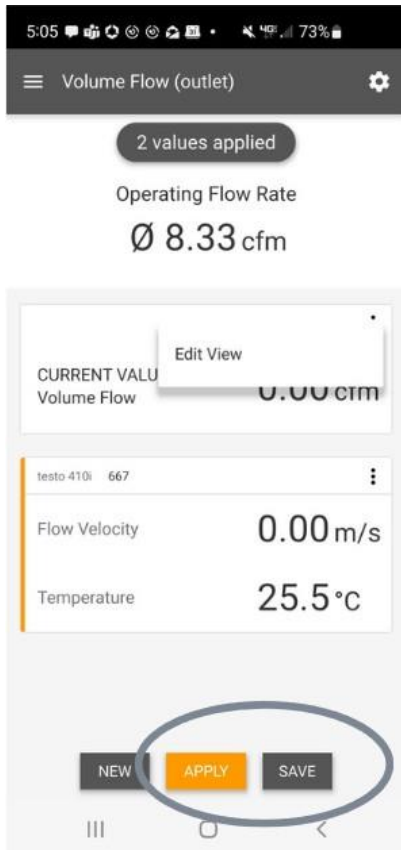

Note: Hitting the Apply and Stop button multiple times will allow you to save multiple readings.

NYCHA STANDARD PROCEDURE MANUAL

E. Appendix E – Instructions for Using a Moisture Meter

1. Moisture meters monitor moisture levels in building materials, and may be helpful for measuring the moisture content in a variety of building materials after water damage. Moisture meters can be used on materials such as carpet, wallboard, wood, brick, and concrete.
2. There are 2 settings for Protimeter Survey: Master and Search (Non Invasive) Mode. Pin-probe readings can provide additional information, but are not used during the root cause assessment. To detect moisture on a surface, inspectors should move the moisture meter across the suspected area.

The moisture meter must be held flush against the wall and not held at an angle while taking measurements.

3. Wet Reading

NYCHA building material is considered “wet” when the moisture meter reading is equal to or greater than 599 (on a scale of 0 to 999).

If the surface displays visible water damage or mold growth, the moisture meter should be moved around to take the reading in six-inch (6”) intervals in each direction, horizontal and vertical, and continue to the point of at least of two feet (2’) beyond any visible water damage or mold growth until moisture meter reading is below 599.

4. Caution-False Reading

The meter is calibrated to detect moisture in building materials composed of organic matter. The meter may report a “999” or other false reading if the instrument detects metal, wire, or tile. If the inspector suspects a false reading, (for example if the moisture meter makes contact with rebar in a Reinforced Concrete Cement (RCC) structure) additional readings should be taken in six-inch intervals in each direction.

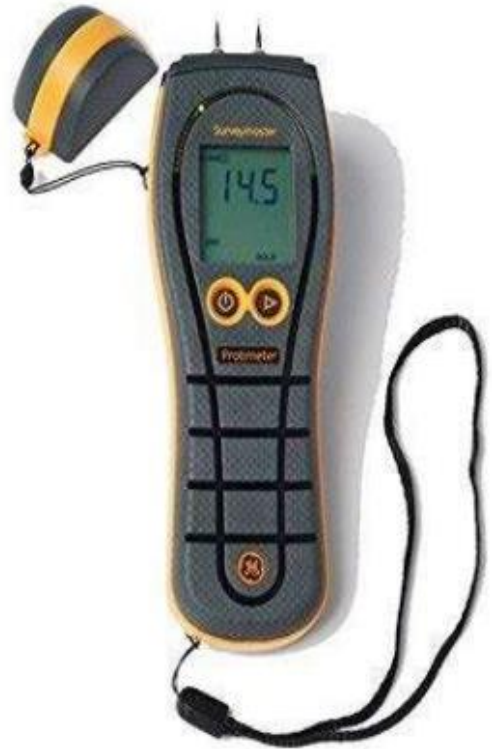

NYCHA STANDARD PROCEDURE MANUAL

F. Appendix F – Creating a Mold Inspection in Apartments on the Handheld

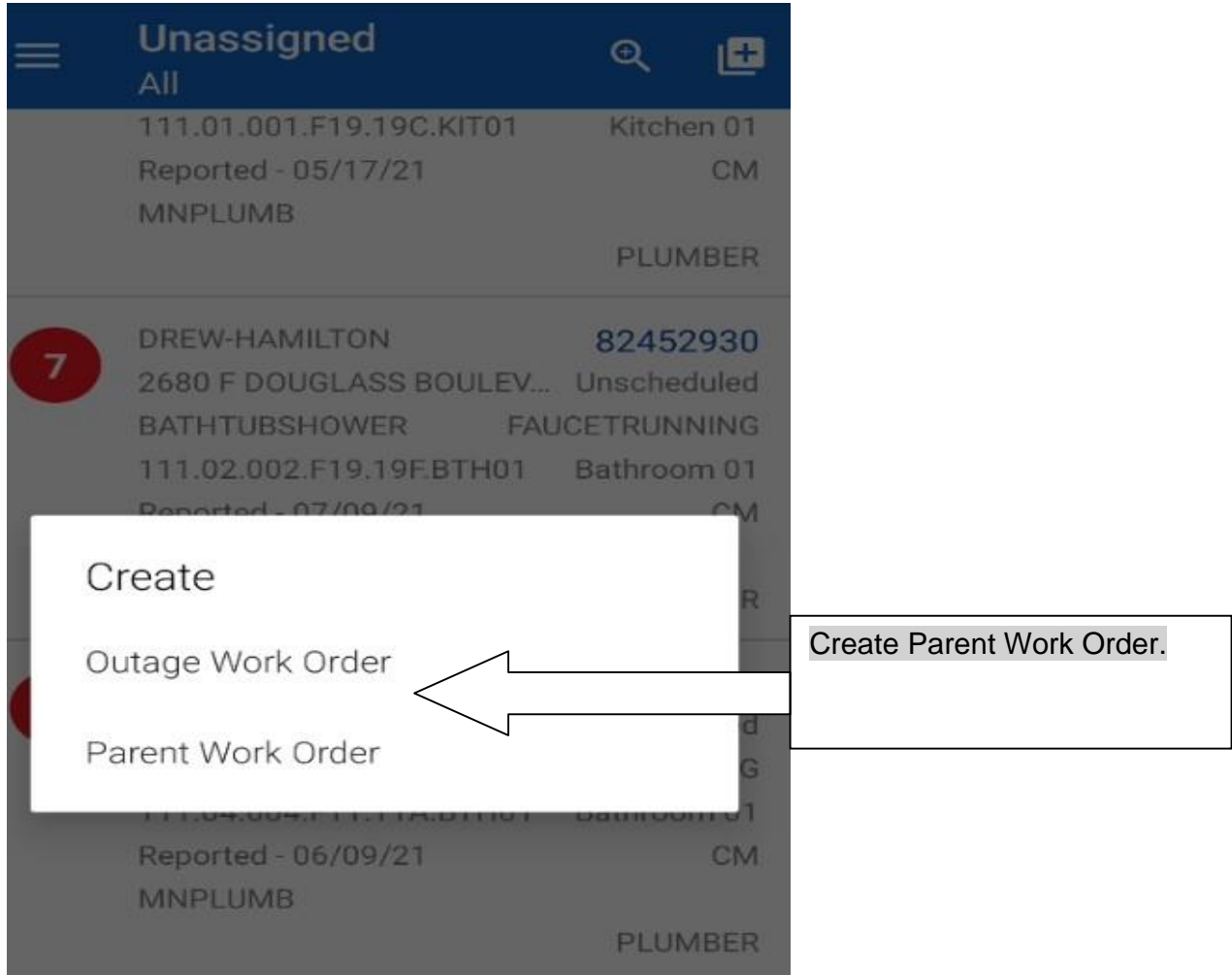

NYCHA STANDARD PROCEDURE MANUAL

← Create Parent Work Or... DONE

Location
111.01.001.F01.01A.BTH01
Bathroom 01

Asset
Please select...

Work Type
CM

Sub Work Type
MOLD
Mold

Failure Class
MILDEWCONDITION
Mold Condition

Problem Code
MILDEW
Mold

Location: Select proper location for Mold Work Order.
Work Type: CM
Sub Work Type: Mold
Failure Class: Mildewcondition
Problem Code: Mildew

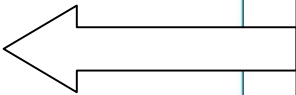

NYCHA STANDARD PROCEDURE MANUAL

← Select Craft 🔍

CARETAKE

Caretaker

CHIEFCTK

Chief Caretaker

LEADINV

Lead Investigator

MAINT

Maintenance

PAINTER

Painter

PLASTER

Plaster

VENDOR

Vendor

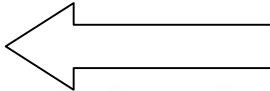

Select CRAFT "MAINT." Craft "SUPER" is not available on IWM as Work Orders on IWM could not be created for SUPT.

NYCHA STANDARD PROCEDURE MANUAL

Work Order Tracking - Welcome to Alina Collins - UAT -- maxuaturl.clamxuo1Node01:9080

Temperature - F: 50.00 Wind Chill - F: 53.00

Work Order: 107812869 * mold Inspection

Asset: >>> Location: 111.01.001.F01A.BTH01 >>> Bathroom 01

Classification: BATHROOM Address: 2660 F DOUGLASS BOULEVARD

Development: DREW/HAMILTON Managed By: 111 DREW

Property Management: MANHATTAN Neighborhood: MR09

* Work Type: CM Sub-Work Type: MOLD VI Child Type: Mold Condition

Failure Class: MILDEWCON Problem Code: MILDEW Severity: Job Plan: INSMOLDCM Craft: SUPT

All Mold Inspections shall be performed by Mold Certified Inspectors

Priority: 6

Priority Justification: Status: APPR Status Date: 11/27/23 5:33 PM Parent WO: >>>

Is Task? Created on Mobile? Created by System: MOBILE

Household Language: English Section 8-Apt? Has Child? Has User Work Logs? Final Complete?

Address Information: Service Address: Formatted Address: Street Address: City: State/Province:

Responsibility: Owner Group: DEVT11 Supervisor: Print Group: Responsible Scheduler: MAXIMO

Work Order Location Information: 504 Residence? Is Tested? Is Abated? Reasonable Accommodation: Asbestos Abated Asbestos Tested Lead Abated Lead Tested Last Inspected Apt Size: 6 Latex Only:

Work Order and Location Additional Details: Child Under 6? Child Under 11? Pregnancy? Senior Citizen? Resident on Life Support? Permission to Enter? Disabled /Waiting? OCC case for Mold/Leads Order by Court? Court Order Mandated Date First Access Date:

Scheduling Information: Inspection Due: Target Start: Target Finish: Scheduled Start: Scheduled Finish: Actual Start: Actual Finish:

Call Center: Siebel SR Number: SR Created By First Name: SR Created By Last Name: SR Created By Phone #: Parent SR: Caller First Name: Caller Phone: Tenant Home Phone: Tenant Work Phone: Tenant Cell Phone: Tenant Emergency Contact: COITA Pest Sensitive: IN

NOTE: In Maximo, WO is defaulted to SUPT.

NYCHA STANDARD PROCEDURE MANUAL

G. Appendix G – Creating a Mold Inspection in Public Spaces and Other Non-Residential Spaces on the Handheld

1. Subwork Type: MILDEWFLWUP
2. Failure Class: MILDEWCONDITION
3. Problem Code: MILDEW
4. Job Plan: M10281
5. Craft: MAINT

Caution: If paint is disturbed, work must be assigned to only RRP-certified staff/vendor and Lead Safe Work Practices must be followed.

Work Order: 108382468 * Mold Work Order Public Space

Asset: >>>

Location: 021.03.007.F01.CC01 >>> Community Center (in original 01A,01B stair-hall 006)

Classification: COMMCNTR

Address: 492 MARCY AVENUE

Development: MARCY

Managed By: 021 MARCY

erty Management: BROOKLYN

Neighborhood: BK06

* Work Type: CM

Sub-Work Type: MILDEWFLW

VI Child Type: >>>

Failure Class: MILDEWCONI >>> Mold Condition

Problem Code: MILDEW >>> Mold

Severity: >>>

Job Plan: M10281 >>> MILDEW CONDITION - MAINT

Craft: MAINT >>>

Responsibility

Owner Group: DEV021

Supervisor: >>>

Print Group: >>>

Responsible Scheduler: MAXIMO

Household Language: >>>

Section 8 Apt?

Has Child?

Has User Work Logs?

Final Complete?

Address Information

Service Address: >>>

Formatted Address: >>>

Street Address: >>>

NYCHA STANDARD PROCEDURE MANUAL

H. Appendix H – Scorecard Factors

1) Median Days to Inspect

Weight = 3

a) Data Points

- i) Mold Busters inspections completed in the last **6 months**
- ii) Mold Busters Inspections currently pending completion

b) Analysis

- i) Days the inspection was open (if completed) or the days pending (if not complete)

c) Calculation

- i) Calculating the median or middle value from the age of all completed and pending inspections

d) Scoring

- i) Per consolidation, the median days to inspect or days pending Inspection

Value	Resulting Score	Weighted Score
< 5	0	0
< 7.5	1	3
< 10	2	6
< 12.5	3	9
< 15	4	12
< 17.5	5	15
< 20	6	18
< 22.5	7	21
< 25	8	24
< 27.5	9	27
>= 27.5	10	30

e) Recommended Actions

- i) Immediately schedule and make attempts on all backlogged (older than 4 days) initial inspections. Monitor development progress on a twice weekly basis in eliminating backlog
- ii) Use 48-hour notice for any apartment that cannot be accessed
- iii) Use dashboards to monitor development performance on initial inspections and contact PMS and APMS if they are failing to make attempts within the 4-day SLA
- iv) Check adequacy of PMS and APMS staffing at the consolidation and make plans to temporarily assign staff or request assistance if there are staffing gaps that are contributing to not meeting the SLA or persistent backlog.

NYCHA STANDARD PROCEDURE MANUAL

2) Skilled Trades Work Orders Older than 100 Days Weight = 3

- a) Data Points
 - i) All open mold and leak work orders (including children, QAs, and reinspections) assigned to a skilled trade craft
- b) Analysis
 - i) Days the work order was open
 - ii) If the work order is older than 100 days old, the work order is categorized as “Over 100 Days”
- c) Calculation
 - i) % of skilled trades work orders over 100 days per consolidation based on the total number of open work orders assigned to a skilled trade craft
- d) Scoring
 - i) Based on the % of skilled trades work orders older than 100 days

Value	Resulting Score	Weighted Score
< 10%	0	0
< 20%	1	3
< 30%	2	6
< 40%	3	9
< 50%	4	12
< 60%	5	15
< 70%	6	18
< 80%	7	21
< 90%	8	24
>= 90%	10	30

- e) Recommended Actions
 - i) Work with the borough offices to assign skilled trade staff to close out individual work orders. Prioritize work orders older than 100 days. Monitor development progress on a weekly basis to ensure that the number of aging skilled trade work orders is declining.
 - ii) Use 48-hour notice for any apartment that cannot be accessed
 - iii) Use dashboards to monitor development performance on scheduling work orders and contact PMS and APMS if developments consistently fail to decrease the number of unscheduled open work orders

NYCHA STANDARD PROCEDURE MANUAL

3) Work Orders Not Scheduled

Weight = 2

a) Data Points

- i) All open mold and leak work orders (including children, QAs, and reinspections)

b) Analysis

- i) Work orders with a scheduled start date that has not already passed will be flagged as “Scheduled in the Future”

c) Calculation

- i) Per consolidation, the % of open work orders with a scheduled start date in the future compared to all other open mold and leak work orders

d) Scoring

- i) Based on % of open work orders with a future scheduled date

Value	Resulting Score	Weighted Score
>= 90%	0	0
>= 80%	1	2
>= 70%	2	4
>= 60%	3	6
>=50%	4	8
>=40%	5	10
>=30%	6	12
>=20%	7	14
>=10%	8	16
< 10%	10	20

e) Recommended Actions

- i) Immediately schedule all open work orders that do not have a scheduled date in the future. Monitor development progress on a twice weekly basis to ensure that all open work orders have a scheduled date.
- ii) Use 48-hour notice for any apartment that cannot be accessed
- iii) Use dashboards to monitor development performance on scheduling work orders and contact PMS and APMS if developments consistently fail to decrease the number of unscheduled open work orders
- iv) Check adequacy of PMS and APMS staffing at the consolidation and make plans to temporarily assign staff or request assistance if there are staffing gaps that are contributing to not meeting the SLA or persistent backlog.

NYCHA STANDARD PROCEDURE MANUAL

4) Founded Mold Busters Work Orders

Weight = 1

a) Data Points

- i) Mold Busters inspections completed in the past **6 months**

b) Analysis

- i) Completed inspections that are founded (inspector found mold, water damage, moisture measurement > 599)

c) Calculation

- i) Percentage of Founded Mold Busters Inspections compared to the total number of completed inspections

d) Scoring

- i) Based on % of founded Mold Busters inspections

Value	Resulting Score	Weighted Score
>= 90%	0	0
>= 80%	1	1
>= 70%	2	2
>= 60%	3	3
>= 50%	4	4
>= 40%	5	5
>= 30%	6	6
>= 20%	7	7
>= 10%	8	8
< 10%	10	10

e) Recommended Actions

- i) Follow-up with mold inspection staff to ensure compliance with mold busters inspection criteria. Where necessary, ensure that staff that need retraining on Mold Busters inspection receive the information they need.
- ii) Use dashboards to monitor development performance on scheduling work orders and contact PMS and APMS if developments consistently report a high number of unfounded Mold Busters Inspections

NYCHA STANDARD PROCEDURE MANUAL

5) QA Inspections Completed on Time

Weight = 1

a) Data Points

- i) Mold Busters QA inspections completed in the last **6 months**

b) Analysis

- i) The number of days it took to complete the QA inspection (Days to Inspect)
(1) If Days to Inspect is 45 or less, the work order is labeled "Under 45 Days to Inspect"

c) Calculation

- i) Percentage of QAs completed in 45 days compared to the total number of completed QA inspections

d) Scoring

- i) Based on the % of Mold Busters QA inspections that were inspected within 45 days

Value	Resulting Score	Weighted Score
>= 90%	0	0
>= 80%	1	1
>= 70%	2	2
>= 60%	3	3
>= 50%	4	4
>= 40%	5	5
>= 30%	6	6
>= 20%	7	7
>= 10%	8	8
< 10%	10	10

e) Recommended Actions

- i) Immediately schedule all backlogged (older than 45 days) QA work orders. Monitor development progress on a twice weekly basis to ensure that all QA work orders have a scheduled date.
- ii) Use 48-hour notice for any apartment that cannot be accessed
- iii) Use dashboards to monitor development performance on scheduling work orders and contact PMS and APMS if developments consistently fail to decrease the number of unscheduled open work orders
- iv) Check adequacy of PMS and APMS staffing at the consolidation and make plans to temporarily assign staff or request assistance if there are staffing gaps that are contributing to not meeting the SLA or persistent backlog.

NYCHA STANDARD PROCEDURE MANUAL

6) Total QAs Passed

Weight = 2

a) Data Points

- i) Mold Busters QA inspections completed on the last **6 months**

b) Analysis

- i) QA inspection fails if the inspector finds one or more of the following
 - (1) Mold Growth, Water Damage, Moisture Measurement > 599
 - (2) Child work orders from the original work order completed improperly

c) Calculation

- i) Percentage of QAs passing inspection per each consolidation

d) Scoring

- i) Based on the % of Mold Busters QA inspections that passed inspection

Value	Resulting Score	Weighted Score
>= 90%	0	0
>= 80%	1	2
>= 70%	2	4
>= 60%	3	6
>= 50%	4	8
>= 40%	5	10
>= 30%	6	12
>= 20%	7	14
>= 10%	8	16
< 10%	10	20

e) Recommended Actions

- i) Follow-up with mold inspection staff to ensure compliance with Mold Busters inspection & remediation criteria. Where necessary, ensure that staff that need retraining on Mold Busters inspection receive the information they need.
- ii) Use dashboards to monitor development performance on QA passage rates. Examine specifically why QAs are failing (major vs. minor fail) and contact PMS and APMS if developments consistently report a high number of failed QAs

NYCHA STANDARD PROCEDURE MANUAL

7) Mold Busters Recurrence Weight = 1

a) Data Points

- i) Mold Busters Inspections created in the past **6 months**
- ii) Cancelled work orders not included

b) Analysis

- i) Any mold inspection created in the same apartment unit and room within 365 days of a previous mold inspection or the closure of a pre-Mold Busters parent
 - (a) Does not include mold inspections created with 30 days of the previous mold inspection
- ii) Any mold inspection created when a previous mold inspection or pre-Mold Busters work order is still open in the same apartment unit and room
 - (a) Does not include mold inspections created with 30 days of the previous mold inspection

c) Calculation

- i) The percentage of Mold Busters recurrence based on the total number of Mold Busters inspections flagged as a recurrence divided by the total number of Mold Busters Inspections created

d) Scoring

- i) Based on the % of Recurrence

Value	Resulting Score	Weighted Score
< 5%	0	0
< 7.5%	2	2
< 10%	4	4
< 12.5%	6	6
< 15%	8	8
>= 15%	10	10

e) Recommended Actions

- i) Follow-up with mold inspection staff to ensure compliance with Mold Busters inspection & remediation criteria. Where necessary, ensure that staff that need retraining on Mold Busters inspection receive the information they need.
- ii) Use dashboards to monitor development performance on recurrence. Examine specifically why recurrence is happening and contact PMS and APMS if developments consistently report a high number of recurrences.

NYCHA STANDARD PROCEDURE MANUAL

8) Time to Respond to Emergency Leaks Weight = 1

a) Data Points

- i) Emergency leak work orders created in the last **6 months**
 - (1) Emergency leaks are leak work orders with a priority of 7, 8, or 9
 - (2) Work orders must have an actual start and actual finish date

b) Analysis

- i) Total time to respond to the emergency leak work order
 - (1) From create date to actual start date
 - (2) If the time to respond is less than 48 hours, the leak work order is considered 48-hour SLA compliant

c) Calculation

- i) Percentage of emergency leak work orders that are compliant based on the total number of emergency leak parents
- ii) Calculated per consolidation

d) Scoring

- i) Based on the % of emergency leak work orders that are compliant

Value	Resulting Score	Weighted Score
>= 90%	0	0
>= 80%	1	1
>= 70%	2	2
>= 60%	3	3
>= 50%	4	4
>= 40%	5	5
>= 30%	6	6
>= 20%	7	7
>= 10%	8	8
< 10%	10	10

e) Recommended Actions

- i) Follow-up with development staff to ensure compliance with leak emergency responses.
- ii) Use dashboards to monitor development performance on response to emergency leaks. Examine specifically why some leaks do not receive an adequate response and contact PMS and APMS if developments consistently report emergency leak compliance issues
- iii) Use 48-hour notice for any apartment that cannot be accessed
- iv) Check adequacy of PMS and APMS staffing at the consolidation and make plans to temporarily assign staff or request assistance if there are staffing gaps that are contributing to not meeting the SLA or persistent backlog.

NYCHA STANDARD PROCEDURE MANUAL

9) Mold Busters Non-Paint Repairs Weight = 3

a) Data Points

- i) Open Mold Busters parents whose non-paint children were completed in the last **6 months**
- ii) Mold Busters parents with open non-paint children
- iii) Only complex work orders are considered (at least 1 skilled trade was in the original work order list)

b) Analysis

- i) For work orders whose non-paint children were completed
(1) Days to complete repairs of the non-paint Children
- ii) For work orders whose non-paint children are still pending
(1) Days pending repair of the non-paint children

c) Calculation

- i) Per consolidation, the median of days to complete non-paint repairs and days pending repair of non-paint children

d) Scoring

- i) Based on the median days to complete non-paint repairs or days pending non-paint repairs

Value	Resulting Score	Weighted Score
< 15	0	0
< 30	1	3
< 40	2	6
< 50	3	9
< 60	4	12
< 70	5	15
< 80	6	18
< 90	7	21
< 100	8	24
< 250	9	27
>= 250	10	30

e) Recommended Actions

- i) Work with the borough offices to assign skilled trade staff to close out individual work orders. Monitor development progress on a weekly basis to ensure that the number of aging skilled trade work orders is declining.
- ii) Use 48-hour notice for any apartment that cannot be accessed
- iii) Use dashboards to monitor development performance on scheduling work orders and contact PMS and APMS if developments consistently fail to decrease the number of unscheduled open work orders

NYCHA STANDARD PROCEDURE MANUAL

10)OCC Tickets

Weight = 1

- a) Data Points
 - i) OCC tickets solved in the last **12 months**
 - ii) OCC Tickets pending solution

- b) Analysis
 - i) If solved - Days between ticket created date and solved date
 - ii) If not solved - Days between the created date and the current date
 - iii) If days to solve or if the days pending is less than or equal to 30 days, the ticket is categorized as "Solved or Pending Solution Under 30 Days"

- c) Calculation
 - i) Per consolidation, the percentage of tickets solved or pending solution under 30 days compared to the total number of OCC tickets solved
 - ii) Only consolidations with at least 15 OCC tickets within the past year will be considered

- d) Scoring
 - i) Based on OCC tickets solved or pending solution within 30 days

Value	Resulting Score	Weighted Score
>= 90%	0	0
>= 80%	1	1
>= 70%	2	2
>= 60%	3	3
>= 50%	4	4
>= 40%	5	5
>= 30%	6	6
>= 20%	7	7
>= 10%	8	8
< 10%	10	10

- e) Recommended Actions
 - i) Follow-up with development staff to ensure compliance with OCC tickets.
 - ii) Use dashboards to monitor development performance on OCC tickets. Examine specifically why OCC tickers are not being solved and contact PMS and APMS if developments consistently report many aging OCC tickets
 - iii) Use 48-hour notice for any apartment that cannot be accessed
 - iv) Check adequacy of PMS and APMS staffing at the consolidation and make plans to temporarily assign staff or request assistance if there are staffing gaps that are contributing to not meeting the SLA or persistent backlog.

NYCHA STANDARD PROCEDURE MANUAL

11) Resident Satisfaction

Weight = 1

a) Data Points

- i) Resident satisfaction results from surveys recorded in the last **12 months**. Surveys are generated from any individual Baez work order (Leaks, Mold Busters, Pre-Mold Busters, QA, or Reinspections).
- ii) Survey must have a valid response to the question “How would you rate your level of satisfaction with the service provided by the NYCHA employee that responded to our service request?”

b) Analysis

- i) Total number of resident satisfaction surveys with a response of Fair, Good, or Excellent

c) Calculation

- i) Per Consolidation, the % of surveys with a response of Fair, Good, or Excellent based on the total number of surveys

d) Scoring

- i) Based on the % of Fair, Good, or Excellent response to Question 4

Value	Resulting Score	Weighted Score
>= 90%	0	0
>= 80%	1	1
>= 70%	2	2
>= 60%	3	3
>= 50%	4	4
>= 40%	5	5
>= 30%	6	6
>= 20%	7	7
>= 10%	8	8
< 10%	10	10

e) Recommended Actions

- i) Use dashboards to monitor development performance on resident satisfaction. Examine specifically why residents are not satisfied and contact PMS and APMS if developments consistently report a low resident satisfaction
- ii) Check adequacy of PMS and APMS staffing at the consolidation and make plans to temporarily assign staff or request assistance if there are staffing gaps that are contributing to not meeting the SLA or persistent backlog.

INTERIM GUIDANCE ON WALL BREAKS

**NEW YORK CITY HOUSING AUTHORITY
MANAGEMENT SERVICES DEPARTMENT**

Interim Guidance on Wall Breaks
Updated: December 16, 2016

When opening a wall to perform or prepare for repairs, staff must take the necessary precautions to protect residents and staff from mold, asbestos, and lead. This guidance (which supplements the wall break procedures detailed in GM3666) details the steps staff must take before, during, and after the wall break. Instructions on temporary wall closures are also included in this guidance; temporary wall closures are an important customer service practice that must be implemented until permanent repairs can be completed.

Maintenance workers, bricklayers, carpenters, plumbers, plasterers and roofers are responsible for performing repairs that require wall breaks, and are responsible for following the below guidance.

Work area preparation

After determining that a wall break must be performed, staff must immediately obtain the necessary supplies before proceeding with repairs. Supplies include, but are not limited to, 6 mil polyethylene sheets, duct tape, a spray bottle, and a sheet of pre-cut Masonite. Lay polyethylene sheets on all horizontal surfaces in the immediate vicinity of the wall opening and secure them with duct tape. **Just prior** to starting work, mist with water the surface area to be opened to reduce the amount of dust produced from the wall break.

If you are working in a development with known lead-based paint or lead components (listed in Appendix A and B of GM3666), polyethylene sheets should cover all horizontal surfaces in the room where the repairs occur. The entrance door should also be covered and weighted at the base to prevent dust from entering other rooms. In these developments, you should make every effort to keep the wall opening under two (2) square feet to limit the amount of dust produced. If the wall break must be greater than two (2) square feet, you must follow the Level 4 dust control instructions detailed in Appendix C of GM3666.

Precautions while performing repairs; temporary wall closure

Where possible, score painted walls with a utility knife or use a pry bar or chisel to open a glazed wall. Sawing and drilling should be avoided, if possible, as they produce significantly more dust and make containment and clean up more difficult.

The wall opening should measure 1' by 1' when done for exploratory purposes (e.g., locating a leak), 2' by 2' for smaller repairs, and 4' by 4' for larger repairs. By opening the wall according to these standard sizes, staff can quickly and easily create a temporary closure using pre-cut Masonite. Developments should maintain a stock of Masonite cut in these sizes to fit the standard wall opening.

Staff **must** make a temporary closure over the opening so that residents are not left with an open wall until final repairs can be completed. Staff should place a pre-cut Masonite sheet over the opening and screw in to secure it. The edges should be covered with duct tape to seal it.

When the wall opening is performed on a tub wall, staff must waterproof the temporary Masonite closure. Use a new piece of polyethylene sheeting to cover the affected wall from the side and top edges to the tub ledge and extend 12 inches past the corner onto the adjacent wall, securing all edges with duct tape. Carefully cut an opening for the tub spout and shower controls, and tape down edges as thoroughly as possible.

Please note: Staff are required to detail that a wall opening has been performed on a tub wall in the notes section of the work order. The subsequent permanent repairs must be expedited in order to prevent potential damage to apartments below. To do so, staff must also notify the development supervisor(s), who will inform the Planning Unit that the follow-up work order must be prioritized.

Clean up

Once the temporary wall closure is complete, use a HEPA-filter vacuum to remove dust, then wet wipe the work area using a clean rag or moistened towel to remove any remaining dust. If you suspect lead is present, use a clean rag or moistened towel with lead-specific detergent to wipe down the work area.

INTERIM GUIDANCE ON PIPE INSULATION

**NEW YORK CITY HOUSING AUTHORITY
MANAGEMENT SERVICES DEPARTMENT**

Interim Guidance on Pipe Insulation
Updated: December 16, 2016

Background

When performing repairs that require a wall break and/or repairs to water/ fire system piping or heat supply lines, NYCHA has the opportunity to quickly and efficiently retrofit piping with insulation in accordance with New York City code.¹ This Interim Guidance provides information on how to inspect and install insulation when a wall break has been performed in the course of completing a repair.

Maintenance workers, bricklayers, carpenters, plumbers, plasterers and roofers are responsible for conducting repairs that require wall breaks and/or repairs to water piping. Thus, maintenance workers and the aforementioned trades will be responsible for following the below guidance.

Process Details

For repairs requiring a wall containing pipes to be opened, maintenance and applicable skilled trades staff are instructed to inspect pipes, valves and fittings exposed for the presence of insulation. For apartment repairs, staff must inspect all domestic water pipes for insulation. In public space, staff must inspect water/ fire system piping or heat supply lines affected by the repair. All new piping (other than waste, vent piping and heat return lines) must be insulated and any repairs that require removal of insulation must include replacing the removed insulation.

If there is no insulation present, staff must install insulation on all pipes, valves and fittings exposed and accessible as a result of the wall break. Where possible, one-inch thick insulation should be installed. If pipe spacing prevents one-inch insulation to be installed, half-inch thick insulation should be installed. Owens Corning ASJ Max insulation of both sizes and related materials (or other manufactured insulation approved by Supply Chain Operations) will be available in the development storeroom for maintenance and skilled trades staff to install on water pipes of various sizes. The full list of insulation and related materials is included in Appendix A. Should they not be available in the development storeroom at the time of the appointment, staff should make a temporary closure to the wall opening using Masonite until the material is obtained at which point work may resume. (Please follow Interim Guidance for Wall Breaks)

Maintenance workers and applicable skilled trades staff are responsible for fully inspecting the pipes exposed and accessible after the wall is opened. Should they find these pipes lack insulation, they must install the insulation during the course of the repair. Staff should consult the manufacturer's installation instructions for additional information. Staff issued with a handheld device must take a photo of the installed insulation once they have completed the installation, select the appropriate insulation remedy codes and attach the photo to the work order in Maximo.

If staff finds that insulation is ripped, damaged or unsecured, staff should remove what remains of the old insulation, and then install insulation around all pipes, valves and fittings that are exposed and accessible as a result of the repair. In the event staff suspects existing insulation may contain asbestos, they are to report it to

¹ 2014 NYC Local Law No. 12, NYC Administrative Code §28-316.1

the development and follow the existing process for testing and abatement. Once insulation has been tested and/or abated, staff should resume installation as outlined above.

Superintendents, assistant superintendents, and skilled trades supervisors are responsible for ensuring that maintenance and skilled trades staff have properly inspected pipes and installed insulation and adhered to policy and procedure outlined in this interim guidance. Superintendents and supervisors should review the work orders where insulation has been installed and view the attached photos to evaluate the installation.

Additionally, superintendents and development staff are responsible for ensuring that an adequate supply of insulation is in stock, monitoring the supply, and ordering additional insulation, when necessary.

Appendix A: Insulation Materials and Supplies	
HA Number	Description
INSULATION	
1207923960*	INSULATION, FIBERGLASS, FOR 1/2" PIPE SIZE, 1/2" WALL THICKNESS, HINGED WITH SELF SEALING LAP, 3 FT LENGTH, OWENS CORNING #722579 OR GRAINGER # 45FM38
1207923801*	FOR 1/2" PIPE SIZE, 1" WALL THICKNESS, HINGED WITH SELF SEALING LAP, 3 FT LENGTH, OWENS CORNING #722470 OR GRAINGER #4LFC9
1207923802	INSULATION, FIBERGLASS, FOR 1/2" PIPE SIZE, 1-1/2" WALL THICKNESS, HINGED WITH SELF SEALING LAP, 3 FT LENGTH, OWENS CORNING #722571 OR GRAINGER #4LFE2
1207923803	INSULATION, FIBERGLASS, FOR 1/2" PIPE SIZE, 2" WALL THICKNESS, HINGED WITH SELF SEALING LAP, 3 FT LENGTH, OWENS CORNING #200257 OR GRAINGER #4LFF4
1207923961*	INSULATION, FIBERGLASS, FOR 3/4" PIPE SIZE, 1/2" WALL THICKNESS, HINGED WITH SELF SEALING LAP, 3 FT LENGTH, OWENS CORNING #722597 OR GRAINGER # 40PP22
1207923804*	FOR 3/4" PIPE SIZE, 1" WALL THICKNESS, HINGED WITH SELF SEALING LAP, 3 FT LENGTH, OWENS CORNING #722471 OR GRAINGER #4LFD1
1207923805	FOR 3/4" PIPE SIZE, 1-1/2" WALL THICKNESS, HINGED WITH SELF SEALING LAP, 3 FT LENGTH, OWENS CORNING #722575 OR GRAINGER #4LFE3
1207923806	FOR 3/4" PIPE SIZE, 2" WALL THICKNESS, HINGED WITH SELF SEALING LAP, 3 FT LENGTH, OWENS CORNING #722619 OR GRAINGER #4LFF5
1207923962*	INSULATION, FIBERGLASS, FOR 1" PIPE SIZE, 1/2" WALL THICKNESS, HINGED WITH SELF SEALING LAP, 3 FT LENGTH, OWENS CORNING #722609 OR GRAINGER # 40PP32
1207923807*	FOR 1" PIPE SIZE, 1" WALL THICKNESS, HINGED WITH SELF SEALING LAP, 3 FT LENGTH, OWENS CORNING #722564 OR GRAINGER #4LFD2
1207923808	FOR 1" PIPE SIZE, 1-1/2" WALL THICKNESS, HINGED WITH SELF SEALING LAP, 3 FT LENGTH, OWENS CORNING #722580 OR GRAINGER #4LFE4
1207923809	FOR 1" PIPE SIZE, 2" WALL THICKNESS, HINGED WITH SELF SEALING LAP, 3 FT LENGTH, OWENS CORNING #722612 OR GRAINGER #4LFF6
1207923963*	INSULATION, FIBERGLASS, FOR 1-1/2" PIPE SIZE, 1/2" WALL THICKNESS, HINGED WITH SELF SEALING LAP, 3 FT LENGTH, OWENS CORNING #722602 OR GRAINGER # 40PP18
1207923810*	FOR 1-1/2" PIPE SIZE, 1" WALL THICKNESS, HINGED WITH SELF SEALING LAP, 3 FT LENGTH, OWENS CORNING #722596 OR GRAINGER #4LFD4
1207923811	FOR 1-1/2" PIPE SIZE, 1-1/2" WALL THICKNESS, HINGED WITH SELF SEALING LAP, 3 FT LENGTH, OWENS CORNING #722594 OR GRAINGER #4LFE6
1207923812	FOR 1-1/2" PIPE SIZE, 2" WALL THICKNESS, HINGED WITH SELF SEALING LAP, 3 FT LENGTH, OWENS CORNING #722606 OR GRAINGER #4LFF8
1207923964**	INSULATION, FIBERGLASS, FOR 2" PIPE SIZE, 1/2" WALL THICKNESS, HINGED WITH SELF SEALING LAP, 3 FT LENGTH
1207923813**	FOR 2" PIPE SIZE, 1" WALL THICKNESS, HINGED WITH SELF SEALING LAP, 3 FT LENGTH, OWENS CORNING #722586 OR GRAINGER #4LFD5

1207923814	FOR 2" PIPE SIZE, 1-1/2" WALL THICKNESS, HINGED WITH SELF SEALING LAP, 3 FT LENGTH, OWENS CORNING #200267 OR GRAINGER #4LFE7
1207923815	FOR 2" PIPE SIZE, 2" WALL THICKNESS, HINGED WITH SELF SEALING LAP, 3 FT LENGTH, OWENS CORNING #722587 OR GRAINGER #4LFF9
1207923816**	FOR 2-1/2" PIPE SIZE, 1" WALL THICKNESS, HINGED WITH SELF SEALING LAP, 3 FT LENGTH, OWENS CORNING #722599 OR GRAINGER #4LFD6
1207923817	FOR 2-1/2" PIPE SIZE, 1-1/2" WALL THICKNESS, HINGED WITH SELF SEALING LAP, 3 FT LENGTH, OWENS CORNING #722583 OR GRAINGER #4LFE8
1207923818	FOR 2-1/2" PIPE SIZE, 2" WALL THICKNESS, HINGED WITH SELF SEALING LAP, 3 FT LENGTH, OWENS CORNING #722589 OR GRAINGER #4LFG1
TAPE	
1207923819	FOR FIBERGLASS PIPE INSULATION, 3" WIDE X 150 FT, PRESSURE SENSITIVE ADHESIVE, RATED 0 TO 150 DEG F., OWENS CORNING #531700 OR GRAINGER #4LFJ3
1207923820	FOR PIPE INSULATION, 1" X 108 FT, PRESSURE SENSITIVE ADHESIVE, RATED 0 TO 150 DEG F., VINYL, OWENS CORNING #PVC201 OR GRAINGER #6WXE4
<p><i>* For insulation marked with a single asterisk (*), developments must maintain a stock of 40 units. For insulation marked with a double asterisk (**), 20 units must be maintained in stock. Developments must also maintain a stock of 10 rolls of both styles of tape.</i></p>	

**ROOF FAN INSPECTIONS AT
NYCHA RESIDENTIAL BUILDINGS
(SP 050:21:1)**

NYCHA STANDARD PROCEDURE MANUAL

SP 050:21:1, ROOF FAN INSPECTIONS AT NYCHA RESIDENTIAL BUILDINGS

TABLE OF CONTENTS

I. PURPOSE	1
II. POLICY.....	1
III. APPLICABILITY.....	1
IV. DEFINITIONS	2
V. REVIEW CYCLE.....	3
VI. RESPONSIBILITIES	3
A. Operations Departments	3
B. Healthy Homes Department	4
C. Office of Quality Assurance.....	4
VII. PROCEDURE.....	4
A. Monthly Roof Fan Inspections.....	4
B. Child Work Orders.....	11
C. Oversight.....	11
VIII. OUTPUTS, REPORTS, AND RECORDKEEPING.....	12
A. Outputs.....	12
B. Reports.....	13
C. Recordkeeping	13
IX. TRAINING REQUIREMENTS.....	13
X. PERFORMANCE METRICS.....	13
XI. NON-COMPLIANCE	13
XII. FORMS.....	13
XIII. WORKFLOW	14
XIV. REVIEW/REVISION HISTORY PAGE.....	15
XV. APPENDICES.....	16
Appendix A – Position Duty Statements.....	16
Appendix B – Override/Bypass Switch Supplemental Information.....	19
Appendix C – Standard Bypass Sign.....	21
Appendix D – Greenheck Roof Fans Information	22

Table of Contents
Page i
Index No. 050:21:1
Issued 7/30/2021

NYCHA STANDARD PROCEDURE MANUAL

NEW YORK CITY HOUSING AUTHORITY

STANDARD PROCEDURE

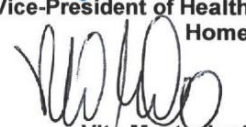
SUBJECT	PROCEDURE OWNER	APPROVED DATE	APPROVED BY	INDEX NO.
ROOF FAN INSPECTIONS AT NYCHA RESIDENTIAL BUILDINGS	HEALTHY HOMES PUBLIC HOUSING OPERATIONS	7/30/2021 Date: _____	 Rassoul Azarnejad Vice-President of Healthy Homes  Vito Mustaciuolo Chief Operating Officer	050:21:1

I. PURPOSE

The purpose of this Standard Procedure is to provide instructions to NYCHA employees to perform inspections, maintenance, and repairs of roof fans.

II. POLICY

It is the policy of NYCHA to:

- A. Ensure roof fans are operating continuously, 24 hours per day, where possible;
- B. Inspect roof fans monthly to ensure roof fans are operating properly;
- C. Conduct detailed quality assurance inspections of roof fans;
- D. Perform preventative maintenance on roof fans;
- E. Return all inoperative or malfunctioning fans to service within 21 calendar days from the date of inspection; and
- F. Follow the requirements of the *Baez et. al. v. NYCHA Modified Amended Stipulation and Order of Settlement* (United States District Court, Southern District of New York).
- G. The inspection instructions in Section VII.A. of this Standard Procedure also are followed if an individual roof fan inspection work order is generated from a mold inspection, leak, or excessive moisture

III. APPLICABILITY

This Standard Procedure applies to all NYCHA employees who perform roof fan inspections in NYCHA public housing developments, and the employees who monitor the inspections. This procedure does not apply to Permanent Affordability Commitment Together (PACT) developments.

NYCHA STANDARD PROCEDURE MANUAL

IV. DEFINITIONS

A. Belt Driven Roof Fan

A type of fan where the fan wheel is affixed to a pulley that is driven by a motor and associated belt.

B. Craft

The type of worker assigned to a work order. For each failure class or problem code, Maximo lists a default craft and other possible crafts that can be assigned. Titles that can be assigned such work orders include roofers, machinists, and electricians.

C. Direct Drive Roof Fan

A type of fan where the fan wheel is directly affixed to the motor.

D. Fan Timer

A device that limits the operating hours of fans; it is NYCHA's policy that all fan timers must be overridden or disconnected to ensure continuous fan operation.

E. High Efficiency Particulate Air (HEPA) Vacuum

A vacuum that uses a HEPA filter and is at least 99.97% efficient in removing microscopic particles (i.e., monodisperse air particles of 0.3 micrometers in diameter).

F. Informer Work Management App (iWM App)

A computer software work order application used by NYCHA to support maintenance and repairs, accessed by employees on handheld devices.

G. Maximo

A computer software application used by NYCHA to support inspections, maintenance, and repairs.

H. Malfunctioning Roof Fan

A roof fan identified during a monthly roof fan inspection as needing repair or replacement. A roof fan is considered to be malfunctioning if it meets one or more of the following conditions: is not operable, no air exhausts from the fan, the fan exhibits excessive noise or vibration, or the belt is not in satisfactory condition.

NYCHA STANDARD PROCEDURE MANUAL

I. Rubber Isolator (Double Studded)

A specialized rubber washer installed on screws used to affix the fan housing to the riser that reduces vibration and noise.

J. Vendor

A third party under contract with NYCHA.

K. Ventilation Riser

A vertical shaft (commonly constructed of galvanized steel) that connects bathroom, kitchen, and common space horizontal vents to roof fans.

V. REVIEW CYCLE

The Healthy Homes Department's Office of Mold Assessment and Remediation and Department of Public Housing Operations shall review this Standard Procedure at least once every three years; and advise the Compliance Department's Procedures Unit via email if no changes are needed or submit its revisions to the procedure by submitting *NYCHA Form 022.008, Procedure Development Request*.

VI. RESPONSIBILITIES

The following departments and titles have responsibilities in this Standard Procedure. See Appendix A - Position Duty Statements, for the summary of duties by title or department.

A. Operations Departments

1. Borough vice-presidents
2. Neighborhood administrators
3. Property managers
4. Property maintenance supervisors
5. Assistant property maintenance supervisors
6. Skilled Trades deputy directors
7. Skilled Trades employees (Property Management)
8. Skilled Trades employees (Technical Services Department)

NYCHA STANDARD PROCEDURE MANUAL

9. Borough Planning supervisors

10. Maintenance workers

B. Healthy Homes Department

1. Office of Mold Assessment and Remediation senior manager

2. Employees in the Office of Mold Assessment and Remediation Analytics and Process Change Unit

C. Office of Quality Assurance

1. Director

2. Inspectors

3. Quality assurance officer

VII. PROCEDURE

A. Monthly Roof Fan Inspections

1. Maximo automatically generates a monthly roof fan inspection work order (IN) for each building that contains roof fans.

a. The work orders are viewable on the iWM App on the handheld devices provided to employees who perform inspections for ease of use and data collection purposes.

NOTE:	If an employee performing roof work observes problems or potential problems with a roof fan, they must create a roof fan inspection work order.
--------------	---

2. The development property maintenance supervisor or assistant property maintenance supervisor monitors Maximo for monthly roof fan inspections.

3. The development property maintenance supervisor, assistant property maintenance supervisor, or maintenance worker (inspector) performs monthly roof fan inspections.

4. Defective roof fans are required to be returned to service within 21 calendar days of a monthly inspection.

a. If an individual roof fan inspection work order is generated as a result of a mold inspection, leak, or excessive moisture, these inspection work orders and related work must be addressed within 21 calendar days.

NYCHA STANDARD PROCEDURE MANUAL

- b. Work orders resulting as a response to a resident complaint regarding apartment ventilation are remediated based on the 21-day period provisions.

NOTE:	If the timeframes related to this Standard Procedure cannot be met because of weather conditions, the inspector adds that information into the notes section of the work order.
--------------	---

5. Fan repairs may be performed by either in-house staff or a vendor.
 - a. If a development has less than 15 roof fans, repairs usually are made by NYCHA employees. If a development has 15 or more roof fans, a vendor performs the repairs.
 - b. If a vendor is required to make roof fan repairs, the inspector contacts the Property Management Borough Office. The Borough Office identifies the vendor and coordinates the repairs.
6. Fan repairs must be made in accordance with the manufacturer's specifications.
7. If a fan motor needs to be replaced and the fan model number cannot be identified because the manufacturer's name plate is illegible or missing, the inspector reviews Development Blueprints or the Document Management and Archival System (DMAS) for Heating and Ventilation plans. To access DMAS, go to nycha.zlinkfm.com. Users must have an account to get access.

NOTE:	To request access to DMAS, go to the Service Desk on the NYCHA Connect home page and select the option for DMAS.
--------------	--

8. Replacement fans must be sized to meet the horsepower, RPM, and other characteristics as per original specifications, with the following exceptions:
 - a. All roof fans are to be replaced with direct drive fans.
 - b. Replacement fans must be specified to operate 24 hours per day, seven days per week.
9. To prepare for the monthly roof fan inspection, the inspector brings the following equipment to the location:
 - a. Equipment to open roof fans (including but not limited to screw drivers).
 - b. Spare fan belts (if belt driven fans are present on the roof).
 - c. Spare bolts, nails, and rubber isolators to make limited repairs described below in section VII.A.10.c.

NYCHA STANDARD PROCEDURE MANUAL

- d. Equipment to access all roof fans on a roof, if required, based on the needs of each development.

NOTE:	Some fans are located on the roof above the elevator machine room or other areas that are elevated above the main roof or on a sub-roof. These areas typically require ladders to access. Detailed roof drawings can be obtained from DMAS. To access DMAS, go to nycha.zlinkfm.com . Users must have an account to get access. See Section VII.A.7. above for instructions on how to request access to DMAS.
--------------	---

10. On the Inspection Tab in Maximo, there are tasks listed with questions for inspectors to answer related to the following items. The inspection questions are available on the handheld device. The answer choices are pre-loaded from Maximo and must be selected by the inspector.

- a. Verifying fan timer overrides.

NOTE:	It is NYCHA's policy that roof fans must be operable for 24 hours per day, seven days per week.
--------------	---

- (1) On the inspection work order, Fan Timer Task, Question 1, asks whether the fan timers have been overridden to allow fans to operate continuously.
- (2) If the fan timers have not been overridden, the inspector:
 - (a) Locates and bypasses the existing roof fan timer(s) by removing the Off Pin and then tripping the Override or Bypass Switch (see Appendix B – Override/Bypass Switch Supplemental Information). Fan timers can be in a basement or a roof top distribution room.
 - (b) After the timers are bypassed, secures the timer cover.
 - (c) Attaches a sign to indicate that the timer was bypassed. Use Appendix C – Standard Bypass Sign.

NYCHA STANDARD PROCEDURE MANUAL

- b. Physically inspecting each roof fan.
- (1) During this phase of the inspection, the inspector determines if the roof fan is in proper working condition by answering the following questions with a 'Yes' or 'No.'
- (a) Is the roof fan operable?
 - (b) Is the air exhausting from the fan?
 - (c) Is the roof fan exhibiting excessive noise or vibration?
- (2) The inspector then is asked to select the fan's motor drive which can be either:
- (a) Belt-driven (typical on older model fans); or
 - (b) Direct-driven (typical on newer model fans).
- (3) If 'belt-driven' is selected, the inspector opens the roof fan housing to observe the belt-driven motor.
- (a) To observe the condition of the belt, the inspector opens the hood and **immediately** shuts down the motor using the switch located within the housing. **This is required to avoid serious injury or death.**
 - (b) The inspector answers 'Is the belt in satisfactory condition?' in one of three ways:
 - i. Yes (satisfactory- belt is not broken, no signs of cracking or cuts)
 - ii. CAT (corrective action taken)

The inspector chooses this if they note a deficiency and correct it successfully. With this selection, Maximo automatically creates a closed work order against the roof fan asset with a failure class of 'ROOFFAN' and a problem code of 'BELTS DML.'
 - iii. No (unsatisfactory- belt is broken or shows **any** signs of visible wear, including cracking or cuts)

The inspector chooses this if they note a deficiency and the deficiency is not corrected. With this selection, Maximo automatically creates a work order against the roof fan asset with a failure class of 'ROOFFAN' and a problem code of 'BELTS DML.'

NYCHA STANDARD PROCEDURE MANUAL

- (4) If 'direct-driven' is selected, the inspector does not answer any more questions regarding the proper working condition of any belt items and proceeds directly below to Section VII.A.10.b.(5).
 - (5) The inspection is complete, and no further questions are asked if the inspector answers:
 - (a) 'Yes' to 'Is the roof fan operable,' **and**
 - (b) 'Yes' to 'Is the air exhausting from the fan,' **and**
 - (c) 'No' to 'Is the roof fan exhibiting excessive noise or vibration,' **and**
 - (d) 'Yes' to 'Is the belt in satisfactory condition' (for belt-driven roof fans).
 - (6) The inspection continues with the items in sections VII.A.10.c. and VII.A.10.d. (directly below) if the inspector answers:
 - (a) 'No' to 'Is the roof fan operable,' **and/or**
 - (b) 'No' to 'Is the air exhausting from the fan,' **and/or**
 - (c) 'Yes' to 'Is the roof fan exhibiting excessive noise or vibration,' **and/or**
 - (d) 'No' to 'Is the belt in satisfactory condition' (for belt-driven roof fans).
- c. For the inspection question determining if the roof fan is exhibiting excessive noise or vibration:
- (1) If the fan is not exhibiting excessive noise or vibration, the inspector responds 'No.'
 - (2) If the fan is exhibiting excessive noise or vibration, the inspector responds 'Yes,' and:
 - (a) Evaluates whether corrective action can be taken during the inspection by performing one or more of the following tasks:
 - i. Tightening, replacing, or installing of appropriate bolts connecting the fan housing to the base plate.
 - ii. Installing new or replacing worn out rubber isolators (double studded) associated with the fan housing bolts.
 - iii. Removing foreign objects located within the fan housing.

NYCHA STANDARD PROCEDURE MANUAL

- (3) If the actions taken during the inspection as outlined directly above in section c.(2)(a) eliminates the excessive noise or vibration, the inspector responds 'CAT' (corrective action taken).
- (a) If corrective action was taken because of the fan wheel, the inspector selects the response 'CAT-FANWHEEL.' Maximo automatically creates a closed work order against the roof fan asset with a failure class of 'ROOFFAN' and a problem code of 'FANHOUSINGDL.'
 - (b) If corrective action was taken because of a loose pulley, the inspector selects the response 'CAT-PULLEY LOOSE.' Maximo automatically creates a closed work order against the roof fan asset with a failure class of 'ROOFFAN' and a problem code of 'PULLEYDAMAGED.'
- (4) If any actions were taken during the inspection, as outlined directly above in section c.(2)(a), but the excessive noise or vibration continues, the inspector chooses one of the following responses:
- (a) If the issue is related to the fan wheel, the inspector selects the response 'YES-FANWHEEL.' Maximo automatically creates a work order against the roof fan asset with a failure class of 'ROOFFAN' and a problem code of 'FANHOUSINGDL.'
 - (b) If the issue is related to a damaged pulley, the inspector selects the response 'YES-PULLEY DAMAGED.' Maximo automatically creates a work order against the roof fan asset with a failure class of 'ROOFFAN' and a problem code of 'PULLEYDAMAGED.'

NYCHA STANDARD PROCEDURE MANUAL

NOTE:	<p>Common causes of excessive noise or vibration include the following:</p> <ol style="list-style-type: none">1. Belt is too tight or too loose2. Defective bearings3. Imbalanced fan wheel4. Wheel improperly aligned and rubbing against the inside of the fan housing5. Loose drive or motor pulleys6. Foreign objects in fan wheel or housing <p>Common causes of reduced air flow include:</p> <ol style="list-style-type: none">1. High system resistance caused by dirty or closed backdraft dampers2. The fan is running backwards3. Excessive dirt buildup on the fan wheel4. Improper wheel alignment <p>Common causes of a non-operational fan motor include:</p> <ol style="list-style-type: none">1. Faulty electrical wiring2. Motor failure <p>Common causes of air not exhausting from a fan:</p> <ol style="list-style-type: none">1. Non-functioning unit2. Bird-screen blocked with heavy dust build-up <p>For manufacturer's troubleshooting and maintenance recommendations, if the fan is a Direct Drive model (G) or Belt Drive model (GB) manufactured by Greenheck, refer to Appendix D, Greenheck Roof Fans Information. If the fan is not a G or GB model manufactured by Greenheck, check the name of the manufacturer and the model number to search online for the appropriate manufacturer's manual.</p>
--------------	---

d. Is there a potential motor failure or no power to the motor?

- (1) If the fan does not have a potential motor failure and there is power to the motor, the inspector responds 'No.'
- (2) If the fan does have a potential motor failure and/or there is no power to the motor, the inspector attempts to fix the issue, if possible. The two main causes of motor failure or no power to the motor are (1) faulty electrical wiring or (2) the motor has reached the end of its lifecycle.
 - (a) If the cause of the motor failure is faulty electrical wiring and the inspector's actions taken during the inspection resolve faulty electrical wiring, the inspector responds 'CAT-FAULTY ELECTRICAL WIRING.' Maximo automatically creates a closed work order against the roof fan asset with a failure class of 'ROOFFAN' and a problem code of 'FANOOO.'

NYCHA STANDARD PROCEDURE MANUAL

- (3) If actions taken during the inspection do not resolve the issue, the inspector chooses one of the following responses:
 - (a) If the issue is faulty electrical wiring, the inspector responds 'YES-FAULTY ELECTRICAL WIRING.' Maximo automatically creates a work order against the roof fan asset with a failure class of 'ROOFFAN' and a problem code of 'FANOOO' or 'EXPOSEDWIRES' or 'FUSEMOOO' or 'NOPOWER.'
 - (b) If the issue is a motor failure, the inspector responds 'YES-MOTOR FAILURE.' Maximo automatically creates a work order against the roof fan asset with a failure class of 'ROOFFAN' and a problem code of 'FANOOO.'

B. Child Work Orders

When a child work order is created during a roof fan inspection:

1. The property maintenance supervisor or assistant property maintenance supervisor coordinates the scheduling of skilled trades crafts with the Property Management Department Planning Unit or Technical Services Department.
2. The Property Management Department skilled trades deputy director or Technical Services Department deputy director assigns the appropriate craft to perform the repairs.
3. Property managers approve any work ordered that is performed by a vendor.

C. Oversight

1. Department of Healthy Homes
 - a. Office of Mold Assessment and Remediation Analytics and Process Change Unit employees review the results of autogenerated monthly roof fan inspections to:
 - (1) Identify developments with lengthy child work order completion time frames (greater than 21 days between the roof fan inspection and repair/replacement of the malfunctioning roof fan);
 - (2) Identify developments with high rates of inoperable roof fans (greater than five percent of the roof fans at the development are reported as inoperable within a single month); and
 - (3) Provide reporting and related actionable recommendations to Operations Management pertaining to developments with lengthy child work order completion time frames and high rates of inoperable roof fans to ensure Baez Consent Decree requirements for roof fans are met.

NYCHA STANDARD PROCEDURE MANUAL

2. Department of Operations
 - a. Borough vice-presidents monitor the progress of child work orders and completion of inspections.
 - b. Neighborhood administrators:
 - (1) Ensure property managers and property maintenance supervisors monitor roof fan-related work orders in Maximo and address conditions in compliance with this Standard Procedure.
 - (2) Follow up with property managers and property maintenance supervisors to address process issues, including but not limited to providing additional training, reviewing key accountabilities, and/or commencing progressive discipline.
 - c. Property maintenance supervisors monitor Maximo for the timely completion of roof fan child work orders and address delays.
 - d. Property Management Department skilled trades deputy directors investigate and respond to reports prepared by the Performance Management Department regarding skilled trades issues.

3. Department of Quality Assurance

The Office of Quality Assurance reviews randomly selected roof fan work orders to ensure that industry standards are being met. Refer to NYCHA Standard Procedure 059:17:1, *Public Housing Quality Assurance Program*. Quality assurance inspectors generate quality assurance inspection work orders from their handheld devices when on-site.

VIII. OUTPUTS, REPORTS, AND RECORDKEEPING

A. Outputs

1. Roof fans operating properly 24 hours per day, seven days per week.
2. Reduced mold conditions in apartments where the root cause was determined to be poor ventilation.
3. All roof fans in NYCHA public housing developments inspected at least once per month.
4. Malfunctioning roof fans repaired or replaced within 21 days of a monthly inspection.

NYCHA STANDARD PROCEDURE MANUAL

B. Reports

1. The Office of Mold Assessment and Remediation provides a quarterly report on the results of roof fan inspections and work completion times.

C. Recordkeeping

1. The Information Technology Department Maximo Unit retains electronically created and stored completed work orders for at least seven years.

IX. TRAINING REQUIREMENTS

- A. All property managers and property maintenance supervisors must review this Standard Procedure and review it with applicable staff.

X. PERFORMANCE METRICS

- A. Completion rate of monthly roof fan inspections.
- B. Number of fan repairs required.
- C. Average time to return roof fans to operation.

XI. NON-COMPLIANCE

- A. NYCHA employees who perform inspections, maintenance, and repairs of roof fans are required to comply with this Standard Procedure.
- B. If unsatisfactory work is identified during either a monthly or quality assurance inspection as described in this Standard Procedure, or at any other time, supervisory employees must:
 1. Identify areas of training for staff and ensure such training is provided.
 2. Reinforce with the relevant employee(s) the job expectations, accountabilities, and the progressive discipline process.
- C. Failure to comply with the requirements of this Standard Procedure may result in disciplinary actions.
- D. Departments are required to take corrective action to bring NYCHA into compliance.

XII. FORMS

This section intentionally left blank.

NYCHA STANDARD PROCEDURE MANUAL

XIII. WORKFLOW

This section intentionally left blank.

NYCHA STANDARD PROCEDURE MANUAL

XIV. REVIEW/REVISION HISTORY PAGE

ROOF FAN INSPECTIONS AT NYCHA RESIDENTIAL BUILDINGS

SP 050:21:1

Review/ Revision	Review/ Revision Date	Sections Amended
1.		
2.		
3.		

NYCHA STANDARD PROCEDURE MANUAL

XV. APPENDICES

Appendix A – Position Duty Statements

1. Operations Departments

a. Borough Vice-Presidents

(1) Monitor the progress of child work orders and completion of inspections.

b. Neighborhood Administrators

(1) Ensure property managers and property maintenance supervisors monitor roof fan-related work orders in Maximo and address conditions in compliance with this Standard Procedure.

(2) Follow up with property managers and property maintenance supervisors to address process issues, including but not limited to providing additional training, reviewing key accountabilities, and/or commencing progressive discipline.

c. Property Managers

(1) Approve any work ordered that is performed by a vendor.

d. Property Maintenance Supervisors

(1) Monitor Maximo for monthly roof fan inspections.

(2) Perform monthly roof fan inspections, including any actions that can be taken during the inspections to eliminate identified problems.

(3) When a work order is created based on an inspection, coordinate the scheduling of skilled trades crafts with the Property Management Department Planning Unit or Maintenance, Repairs, and Skilled Trades Department.

(4) Monitor Maximo for the timely completion of roof fan child work orders and address delays.

e. Assistant Property Maintenance Supervisors

(1) Monitor Maximo for monthly roof fan inspections.

(2) Perform monthly roof fan inspections, including any actions that can be taken during the inspections to eliminate identified problems.

NYCHA STANDARD PROCEDURE MANUAL

- (3) When a work order is created based on an inspection, coordinate the scheduling of skilled trades crafts with the Property Management Department Planning Unit or Maintenance, Repairs, and Skilled Trades Department.
- f. Skilled Trades Deputy Directors
 - (1) Assign the appropriate craft to perform repairs. Skilled Trades titles that perform work on roof fans include roofers, machinists, and electricians.
 - (2) Investigate and respond to reports prepared by the Performance Management Department regarding skilled trades issues.
 - g. Skilled Trades Employees (Property Management)
 - (1) Perform the work created by child work orders.
 - h. Skilled Trades Employees (Technical Services Department)
 - (1) Perform the work created by child work orders.
 - i. Borough Planning Unit Supervisors
 - (1) When a work order is created based on an inspection, coordinate the scheduling of skilled trades crafts with the property maintenance supervisor.
 - j. Maintenance Workers
 - (1) Perform monthly roof fan inspections, including any actions that can be taken during the inspections to eliminate identified problems.
2. Department of Healthy Homes
 - a. Office of Mold Assessment and Remediation Senior Manager
 - (1) Manages the duties performed by Office of Mold Assessment and Remediation employees in this standard procedure.
 - b. Employees in the Office of Mold Assessment and Remediation Analytics and Process Change Unit
 - (1) Review the results of autogenerated monthly roof fan inspections.

NYCHA STANDARD PROCEDURE MANUAL

3. Office of Quality Assurance

a. Director

(1) Performs duties as outlined in NYCHA Standard Procedure 059:17:1, *Public Housing Quality Assurance Program*.

b. Inspectors

(1) Perform duties as outlined in NYCHA Standard Procedure 059:17:1, *Public Housing Quality Assurance Program*.

c. Quality Assurance Officer

(1) Perform duties as outlined in NYCHA Standard Procedure 059:17:1, *Public Housing Quality Assurance Program*.

NYCHA STANDARD PROCEDURE MANUAL

Appendix B – Override/Bypass Switch Supplemental Information

Typical Time Clock

1. Remove On/Off Pins- Blue Arrows
2. Lift Protective Wire Cover
3. Trip Override lever into On Position
4. Verify Roof Fans Operating
5. Close Cover and Secure
6. Post Signage stating clock on Bypass



Override Lever



NYCHA STANDARD PROCEDURE MANUAL

Time Clock equipped with Separate Bypass Switch

1. Remove On/Off Pins- Blue Arrow
2. Trip Override Lever into On Position or
use manual Bypass Switch- Green Arrows
3. Verify Roof Fans Operating
4. Close Cover and Secure
5. Post Signage stating Clock on Bypass



Appendix C – Standard Bypass Sign

**ATTENTION:
TIMER IS
ON BYPASS.**

**ROOF FAN
MUST OPERATE
CONTINUOUSLY.**

NYCHA STANDARD PROCEDURE MANUAL

Appendix D – Greenheck Roof Fans Information

Direct Drive

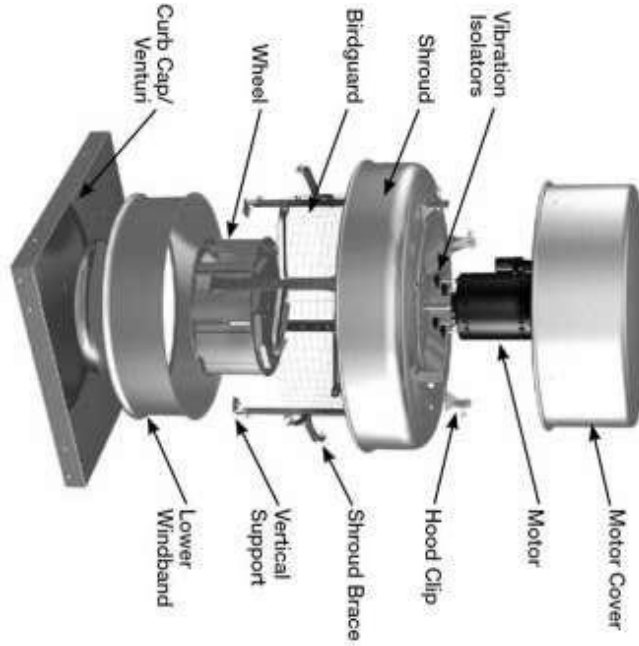

Belt Drive

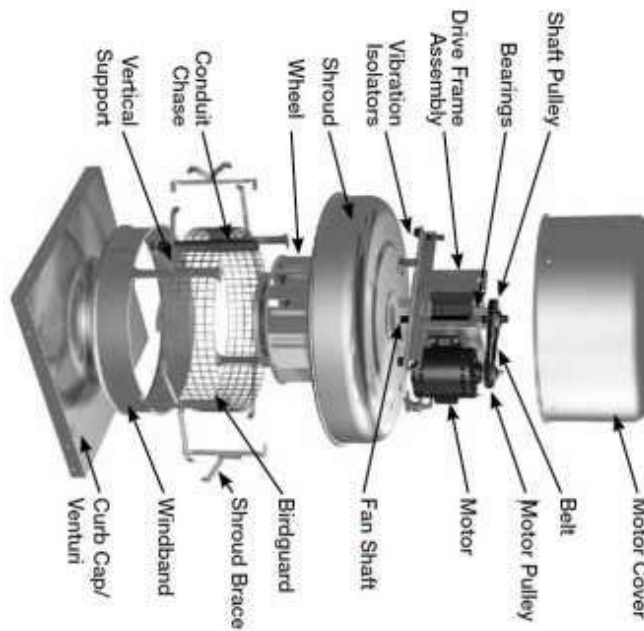

Direct Drive

Figure 4 - Typical Roof Mounting Installation

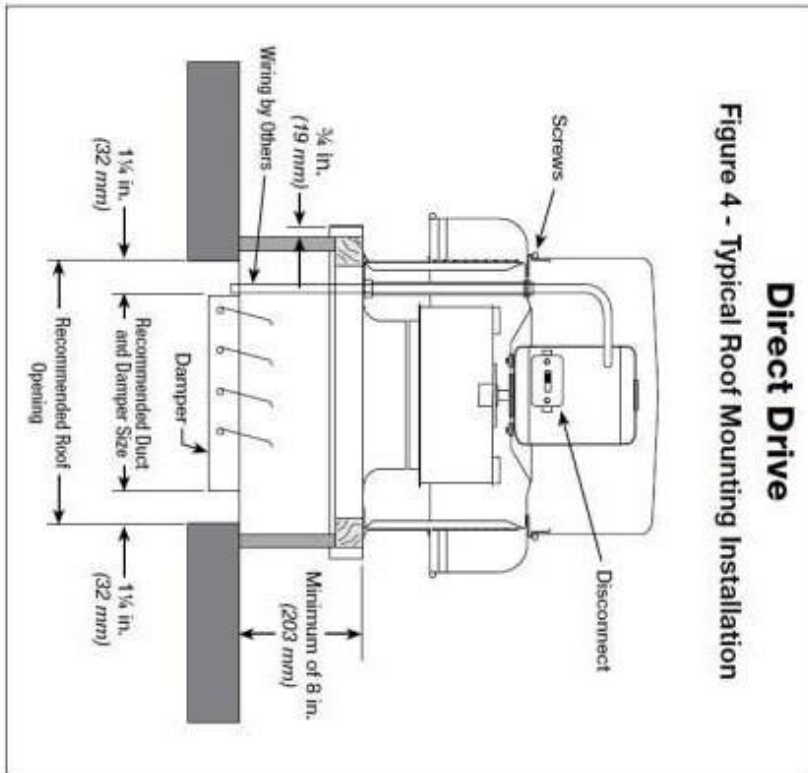

Belt Drive

Figure 5 - Typical Roof Mounting Installation

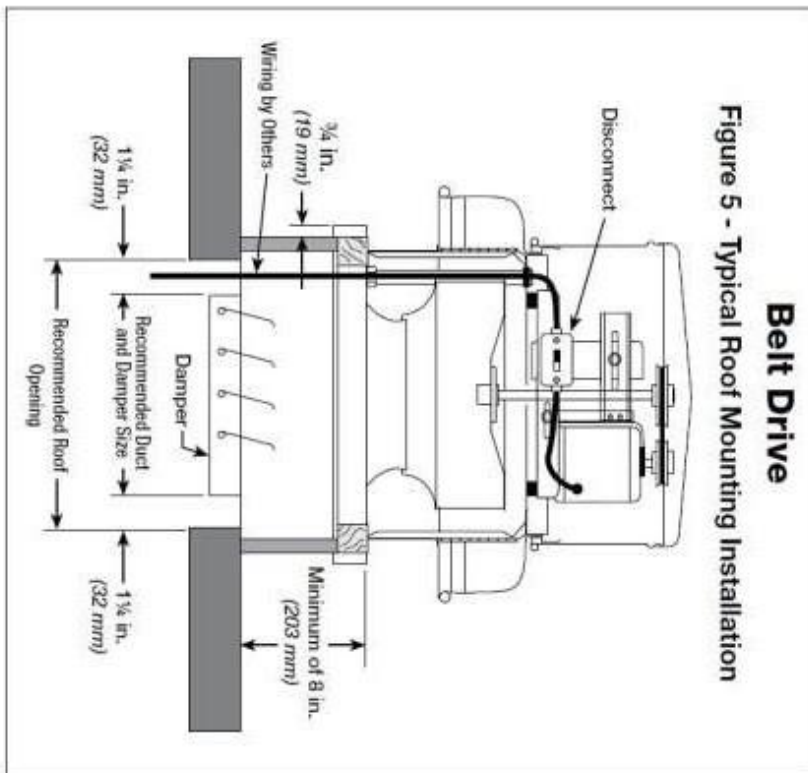

NYCHA STANDARD PROCEDURE MANUAL

PROBLEM	CAUSE	CORRECTIVE ACTION
Excessive noise or vibration	Wheel rubbing inlet	Adjust wheel and/or inlet cone. Tighten wheel hub or bearing collars on shaft.
	V-belt drive	Tighten pulleys on motor/fan shaft. Adjust belt tension. Align pulleys properly; see page 6, Figures 9 and 10. Replace worn belts or pulleys.
	Bearings	Replace defective bearing(s). Lubricate bearings. Tighten collars and fasteners.
	Wheel unbalance	Clean all dirt off wheel. Check wheel balance, rebalance in place if necessary.
	Belts too tight or too loose	Adjust tension, see page 7, Figure 12a-b.
	Wheel improperly aligned and rubbing	Center wheel on inlet, see page 6, Figure 7.
	Loose drive or motor pulleys	Align and tighten. See "Pre-Starting Checks", see page 6 and 7.
	Foreign objects in wheel or housing	Remove objects, check for damage or unbalance.
	Fan base not securely anchored	Secure properly.
	Motor hood loose and rattling	Tighten fasteners to secure the motor hood.
	Defective or loose motor bearings	Replace motor with same frame size, RPM-HP.
High horsepower	Fan	Check rotation of wheel, see page 6, Figure 8. Reduce fan speed.
	Duct system	Resize ductwork. Check proper operation of face and bypass dampers. Check filters and access doors.
Fan does not operate	Electrical supply	Check fuses/circuit breakers. Check for switches off. Check for correct supply voltage.
	Drive	Check for broken belts. Tighten loose pulleys or belts.
	Motor	Ensure motor is correct horsepower and not tripping overload protector.
Motor overloads or overheats	Lubrication	Check for excessive or insufficient grease in the bearing.
	Mechanical	Replace damaged bearing. Relieve excessive belt tension. Align bearings. Check for bent shaft.
	Belt slippage	Adjust tension or replace bad belts, see pages 6 and 7.
	Over/Under line voltage	Contact power company.
	Incorrect wheel rotation	Check motor wiring, see page 5, Figure 4. Confirm wheel rotation, see page 6, Figure 8.
	Wheel RPM too high	Check drives or slow down fan by opening variable pitch pulley on motor shaft.
	Undersized motor	Check motor ratings with catalog speed and air capacity chart.
Motor wired incorrectly	Check motor wiring to wiring diagram located on fan motor.	
Reduced airflow	System resistance too high	Check system: Proper operation of backdraft or control dampers, obstruction in ductwork, clean dirty filters.
	Unit running backwards	Correct as shown on page 6, Figure 8.
	Excessive dirt buildup on wheels	Clean wheel.
	Improper wheel alignment	Center wheel on inlet, see "Pre-Starting Checks" on page 6.
	Dampers closed	Inspect and repair.
	Blocked duct/clogged filter	Clean or replace.
	Belt slippage	Replace and adjust tension.
Speed too slow	Check for correct drives.	

NYCHA STANDARD PROCEDURE MANUAL

Model Number Code

The model number code system is designed to completely identify the fan. The correct code letters must be specified to designate belt or direct drive. The remainder of the model code is determined by the size and performance.

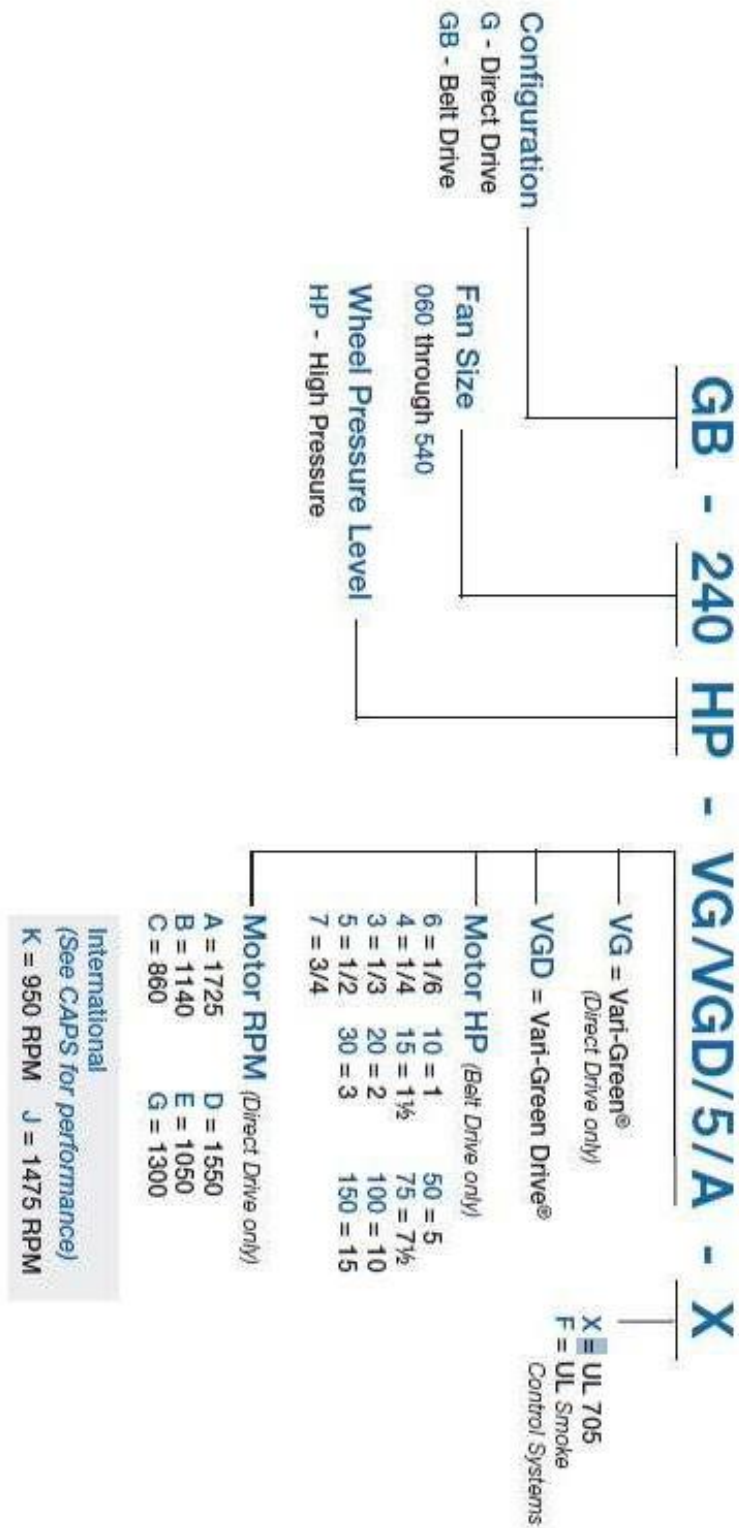

**NYCHA STANDARD PROCEDURE MANUAL
(SP 040:18:2)
LEAD SAFETY FOR RENOVATION, REPAIR &
PAINTING**



NYCHA STANDARD PROCEDURE MANUAL

SP 040:18:2, LEAD SAFETY FOR RENOVATION, REPAIR, AND PAINTING

TABLE OF CONTENTS

I. PURPOSE	1
II. POLICY.....	1
III. APPLICABILITY.....	1
IV. DEFINITIONS.....	2
V. REVIEW CYCLE.....	4
VI. RESPONSIBILITIES.....	4
A. Operations Departments	4
B. Lead Hazard Control Department.....	5
C. Human Resources Department.....	5
VII. WORKFLOW	6
VIII. PROCEDURE.....	14
A. Assigning Certified Renovators	14
B. Pre-Renovation Notice to Residents	17
C. Dust Wipe Work Orders.....	19
D. Renovation, Repair, and Painting Work	20
E. Employee Safety	21
F. Supplies	21
G. Setting Up	23
H. Performing Work	26
I. Cleaning Up	27
J. Clearance.....	29
K. Work Disturbing More Than 100 Square Feet or Removing Two or More Painted Windows ...	30
IX. OUTPUTS, REPORTS, AND RECORDKEEPING.....	32
A. Outputs.....	32
B. Reports.....	32
C. Recordkeeping.....	32
X. TRAINING REQUIREMENTS.....	32
XI. PERFORMANCE METRICS.....	33
XII. NON-COMPLIANCE	33
XIII. FORMS.....	33
XIV. REVIEW/REVISION HISTORY PAGE.....	34
XV. APPENDICES.....	35
A. Lead Safe Practices Vendor Notice.....	35
B. RRP Supplemental Workflow	37

Table of Contents
Page i
Index No. 040:18:2
Issued 12/31/2018

SUBJECT	PROCEDURE OWNER	APPROVED DATE	APPROVED BY	INDEX NO.
LEAD SAFETY FOR RENOVATION, REPAIR, AND PAINTING	OPERATIONS	Date: <u>12/31/18</u>	 Cathy Pennington Executive Vice-President of Operations  Tom Mustaciolo General Manager	040:18:2

I. PURPOSE

The purpose of this Standard Procedure is to provide instructions to employees on how to comply with applicable federal and local lead-based paint requirements when performing renovation, repair, and painting (RRP) work in public housing apartments, common areas, or exteriors where lead-based paint may be present.

This Standard Procedure does not provide complete operational instructions for performing RRP work. For more detailed information, please refer to the *Renovation, Repair, and Painting Training Manual* on the Forms and Reference Library in the Other Publications section.

II. POLICY

It is the policy of NYCHA to follow the requirements set forth in federal and local laws and regulations for performing RRP work, including but not limited to:

- A. Lead-Based Paint Poisoning Prevention Act, as amended (42 U.S.C. 4821 et seq.)
- B. Residential Lead-Based Paint Hazard Reduction Act of 1992 (42 U.S.C. 4851 et seq.)
- C. U.S. Department of Housing and Urban Development (HUD) regulations at 24 CFR Part 35 ("Lead Law")
- D. U.S. Environmental Protection Agency (EPA) regulations at 40 CFR Part 745 Subpart E ("RRP Rule")
- E. Local Law 1, NYC Admin. Code §§ 27-2056 ("New York City Childhood Lead Poisoning Prevention Act of 2003")

III. APPLICABILITY

Maximo flags locations in which lead-based paint is or may be present, and identifies when RRP requirements must be met. If a Maximo work order identifies that RRP is required, all painted surfaces must be presumed to be lead-based paint.

NYCHA STANDARD PROCEDURE MANUAL

This Standard Procedure applies to all RRP work in apartments, common areas, or exteriors, if Maximo identifies the work order as such, and if:

- A. The work disturbs two (2) square feet or more of presumed lead-based paint per room, or more than 10 percent of a single small component per room, in apartments and common areas; or
- B. The work disturbs more than 20 square feet of lead-based paint on exteriors.

IV. DEFINITIONS

A. Certified Renovator

An individual who successfully completes a renovator course accredited by the federal Environmental Protection Agency (EPA) or an EPA-authorized State or Tribal program.

B. Child-Occupied Facility

A building, or portion of a building, constructed prior to 1978, that meets all three (3) of the following conditions:

- 1. Visited regularly by the same child, younger than six (6) years old;
- 2. The visits are on at least two different days within any week, provided that each day's visit lasts at least three (3) hours; and
- 3. Combined weekly visits last at least six (6) hours, and the combined annual visits last at least 60 hours.

C. Common Area

Part of a residential property available for use by occupants of more than one apartment, including, but not limited to, hallways, stairways, laundry rooms, recreational rooms, community centers, on-site day care facilities, garages, and exteriors.

D. Component

A specific design or structural element or fixture distinguished by its form, function, and location. Examples include, but are not limited to:

- 1. Counter tops
- 2. Doors and trim
- 3. Walls

NYCHA STANDARD PROCEDURE MANUAL

4. Window sills and sashes

5. Windows and trim

E. Containment

A system of temporary barriers used to isolate a work area so that no dust or debris escapes while work is being performed.

F. Disposable Soft Wipe Method

A method of cleaning that uses a flip mop with wet disposable soft wipes.

G. Disturbed Paint Surface

A paint surface that is scraped, sanded, cut, penetrated, or otherwise affected by work in a manner that could potentially create a lead-based paint hazard by generating dust, fumes, or paint chips.

H. Dust Clearance Examination

An examination to confirm no lead dust remains in a work area after it is cleaned. The examination includes a visual inspection and a dust wipe.

I. Emergency Renovations and Repairs

Unscheduled renovation and repair activities that were not planned but result from a sudden, unexpected event that, if not immediately attended to, presents a safety or public health hazard, or threatens equipment and/or property with significant damage.

J. Exterior

Any area outside of a building, including but not limited to exterior walls, playgrounds, and boundary fences.

K. HEPA Vacuum

A vacuum with filters that is capable of trapping extremely small particles. HEPA stands for High-Efficiency Particulate Air.

L. Maximo

A computer software application used by NYCHA to support maintenance and repairs.

NYCHA STANDARD PROCEDURE MANUAL

M. Renovation

Any activity that disturbs painted surfaces and includes most repair, remodeling, and maintenance activities including windows replacement.

N. Renovation, Repair, and Painting (RRP) Certification

A certification provided by trainers approved by the EPA after a worker has successfully completed a Certified Renovator training program. A worker must have up-to-date RRP certification to perform RRP work that might disturb lead-based paint.

O. Two-Bucket Method

A method of cleaning that uses one bucket filled with a cleaning agent/water solution, and another bucket filled with clean water.

P. Vendor

A third party under contract with NYCHA.

V. REVIEW CYCLE

The Department of Operations shall review this Standard Procedure every one (1) year, or earlier if necessary; and advise the Department of Procedures Development and Administration via e-mail if no changes are needed, or submit its revisions to the procedure by submitting NYCHA Form 022.008, *Procedure Development Request*.

VI. RESPONSIBILITIES

This Standard Procedure applies to the following titles who may perform RRP work, and their supervisors:

A. Operations Departments

1. Property Managers
2. Assistant Property Managers
3. Property Maintenance Supervisors
4. Assistant Property Maintenance Supervisors
5. Maintenance Workers
6. Supervisor Bricklayers

NYCHA STANDARD PROCEDURE MANUAL

7. Bricklayers
 8. Supervisor Carpenters
 9. Carpenters
 10. Supervisor Painters
 11. Painters
 12. Apprentices (Painter)
 13. Supervisor Plasterers
 14. Plasterers
 15. Supervisor Plumbers
 16. Plumbers
 17. Plumber's Helpers
 18. Electricians
 19. Emergency Services Aides
 20. Caretaker Ps
 21. Mason's Helpers
 22. Asbestos Handlers
- B. Lead Hazard Control Department
1. Lead Abatement Workers
 2. Contract Administrator
 3. Environmental Health and Safety Coordinator
- C. Human Resources Department
1. Deputy Director of Learning and Development

NYCHA STANDARD PROCEDURE MANUAL

VII. WORKFLOW

In addition to the flow charts which begin on the following page, also refer to Appendix XV.B., RRP Supplemental Workflow.

Process 1: Maintenance Worker Verifies Complaint

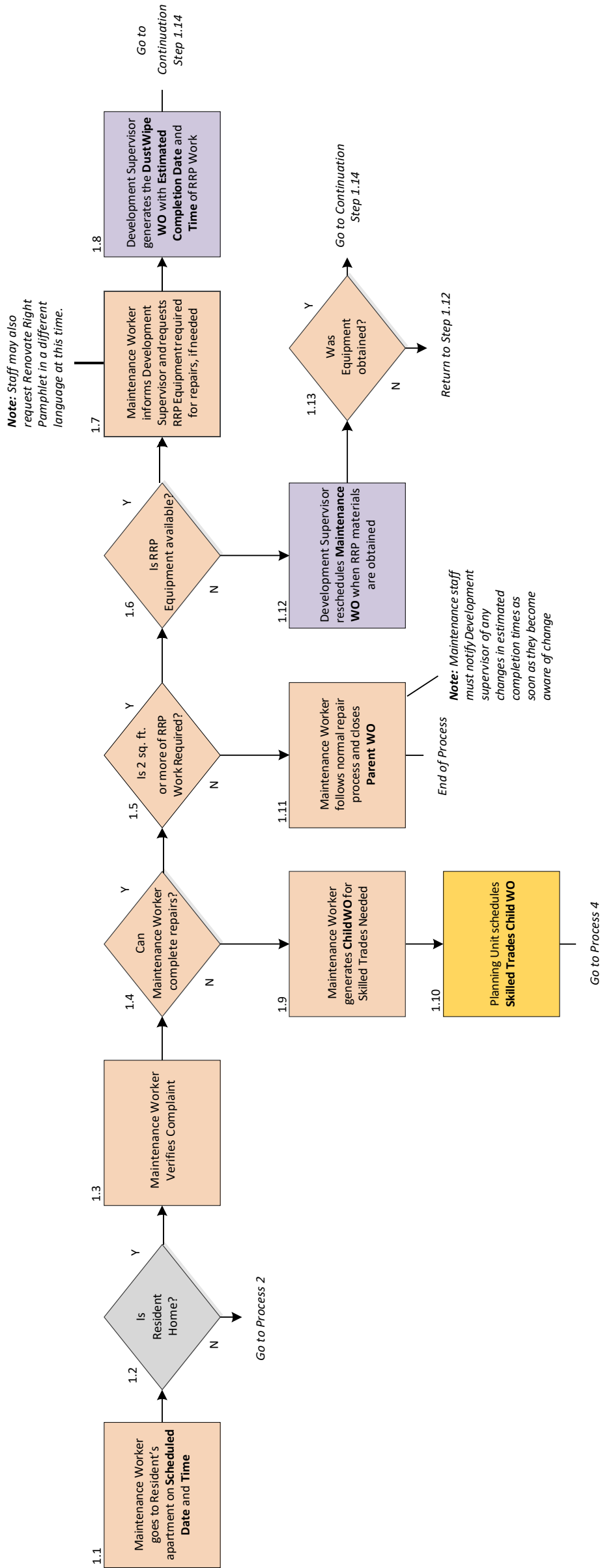

Process 1: Maintenance Worker Verifies Complaint (Continuation)

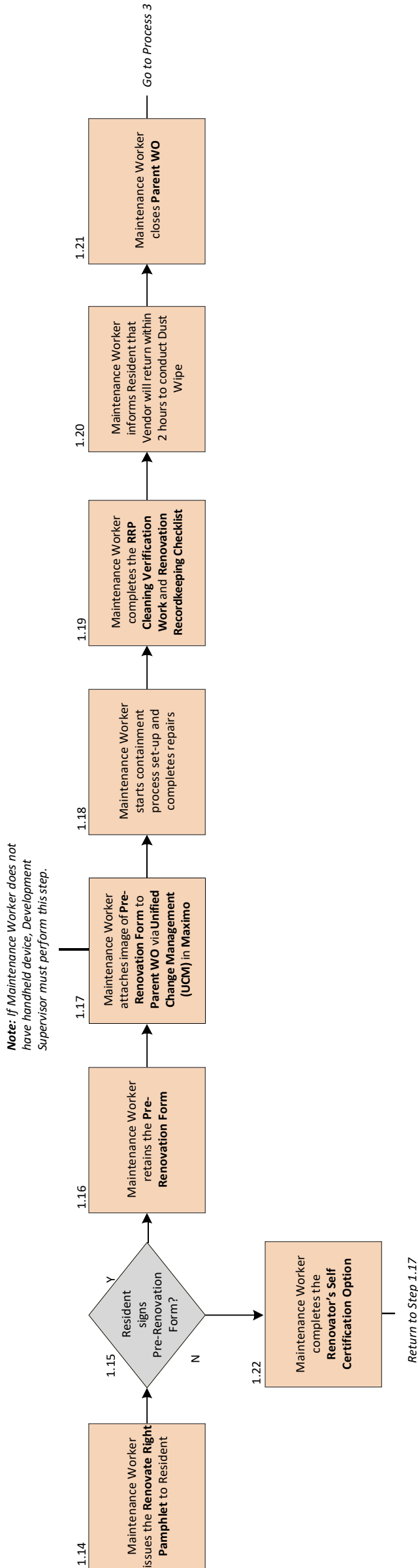

Process 2: Tenant Not Home

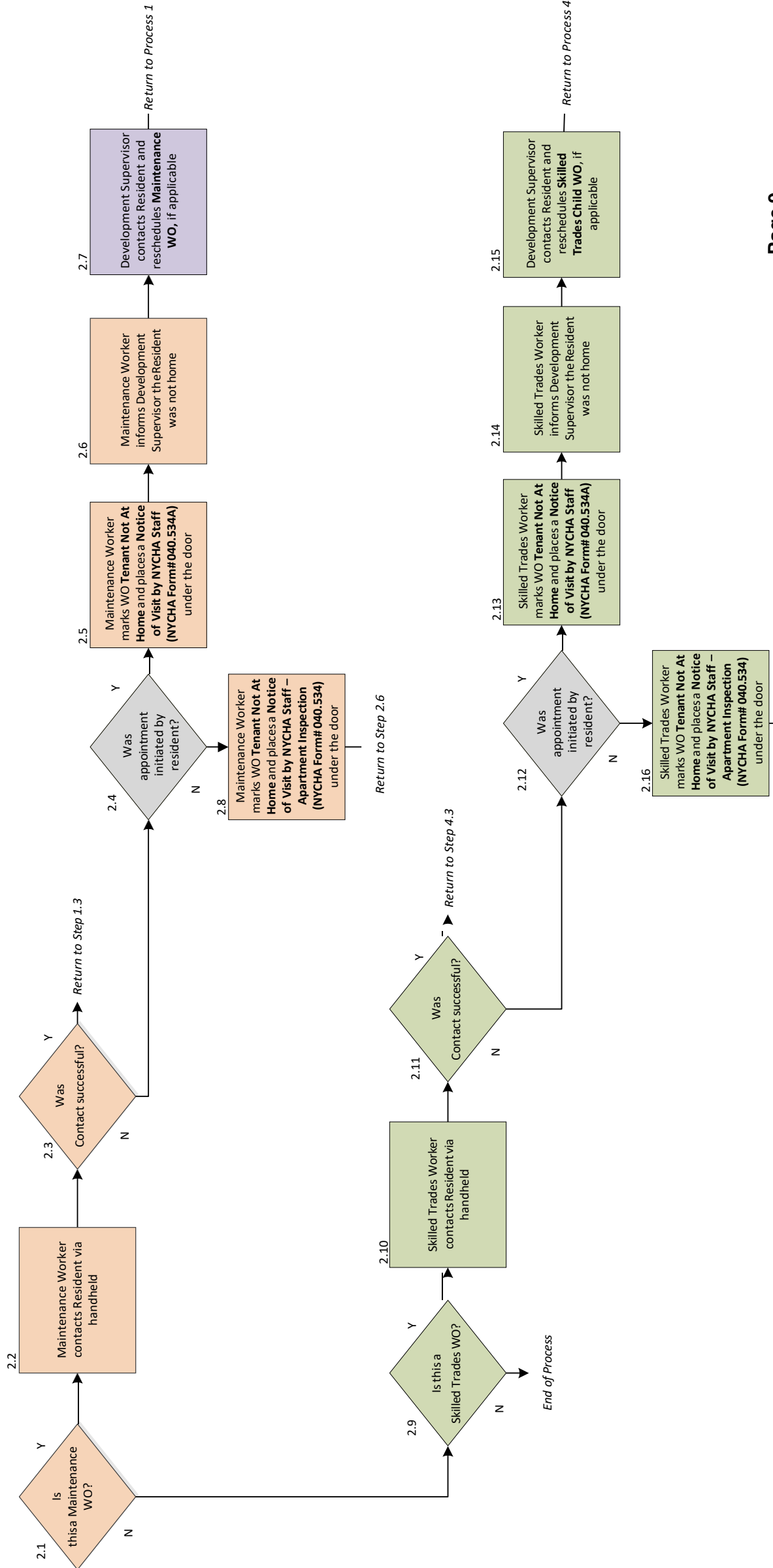

Process 3: Vendor Conducts Dust Clearance Examination

Note: Dust Clearance results may be available within 8 hours dependent on date and time of collection.

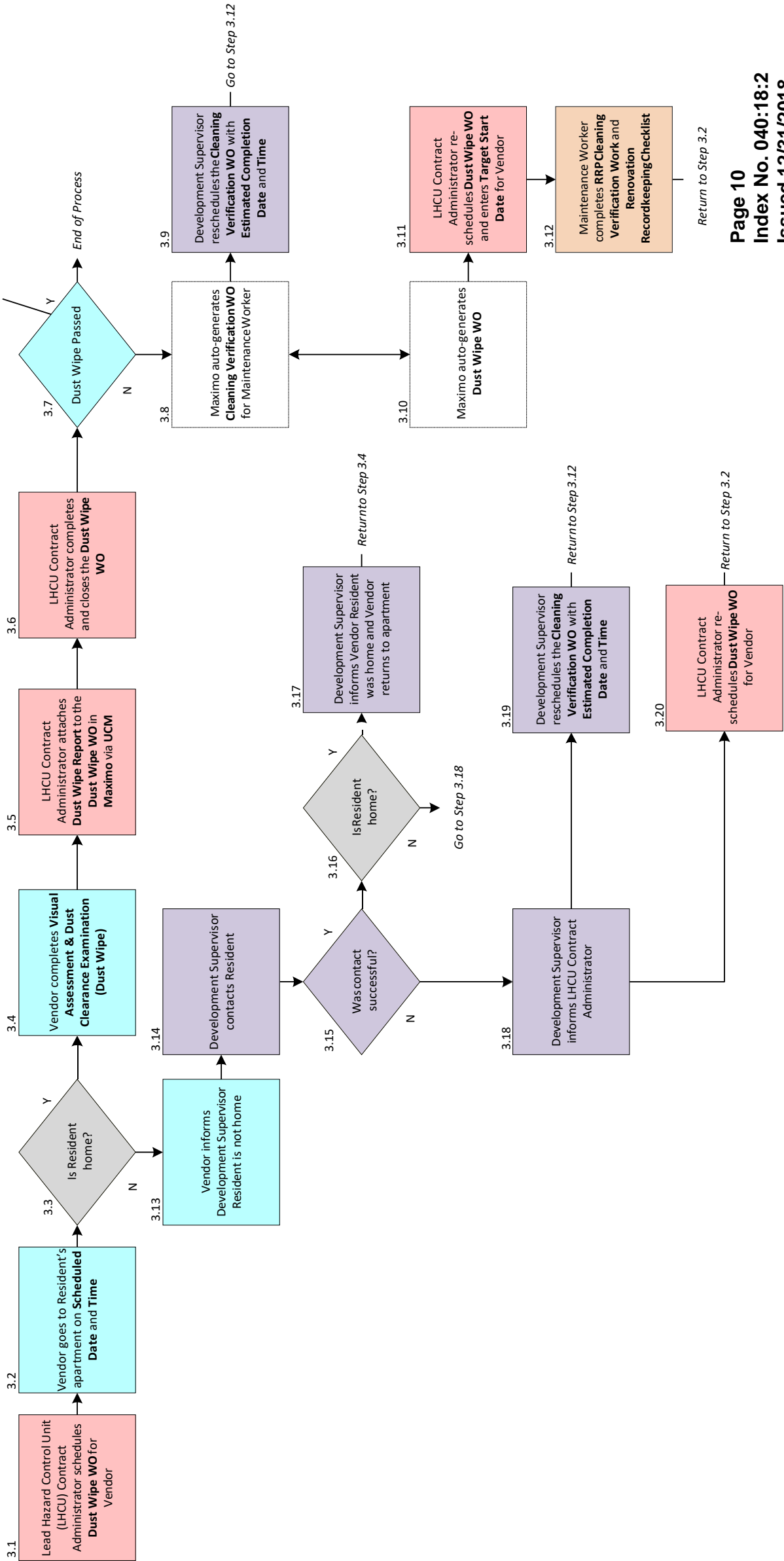

Process 4: Skilled Trades Verifies Complaint

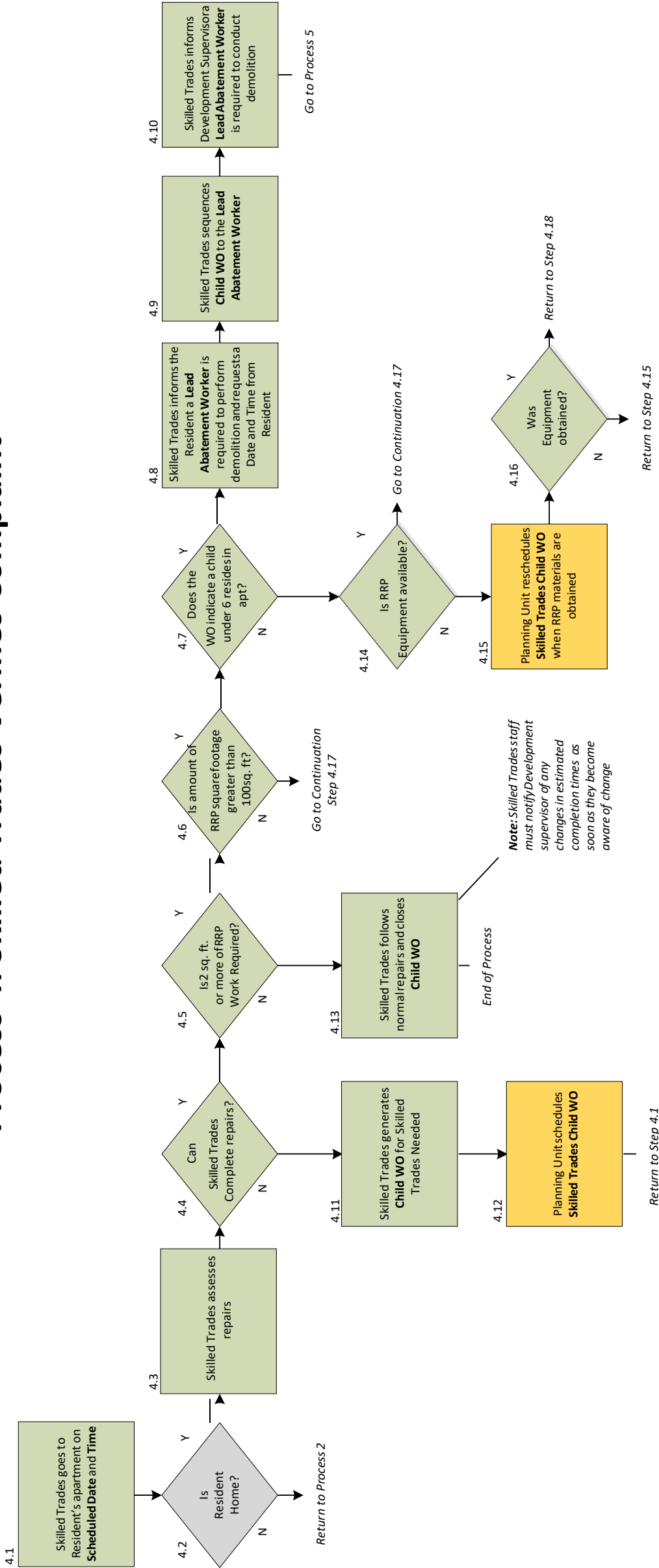

Note: Skilled Trades staff must notify Development supervisor of any changes in estimated completion times as soon as they become aware of change

Process 4: Skilled Trades Verifies Complaint (Continuation)

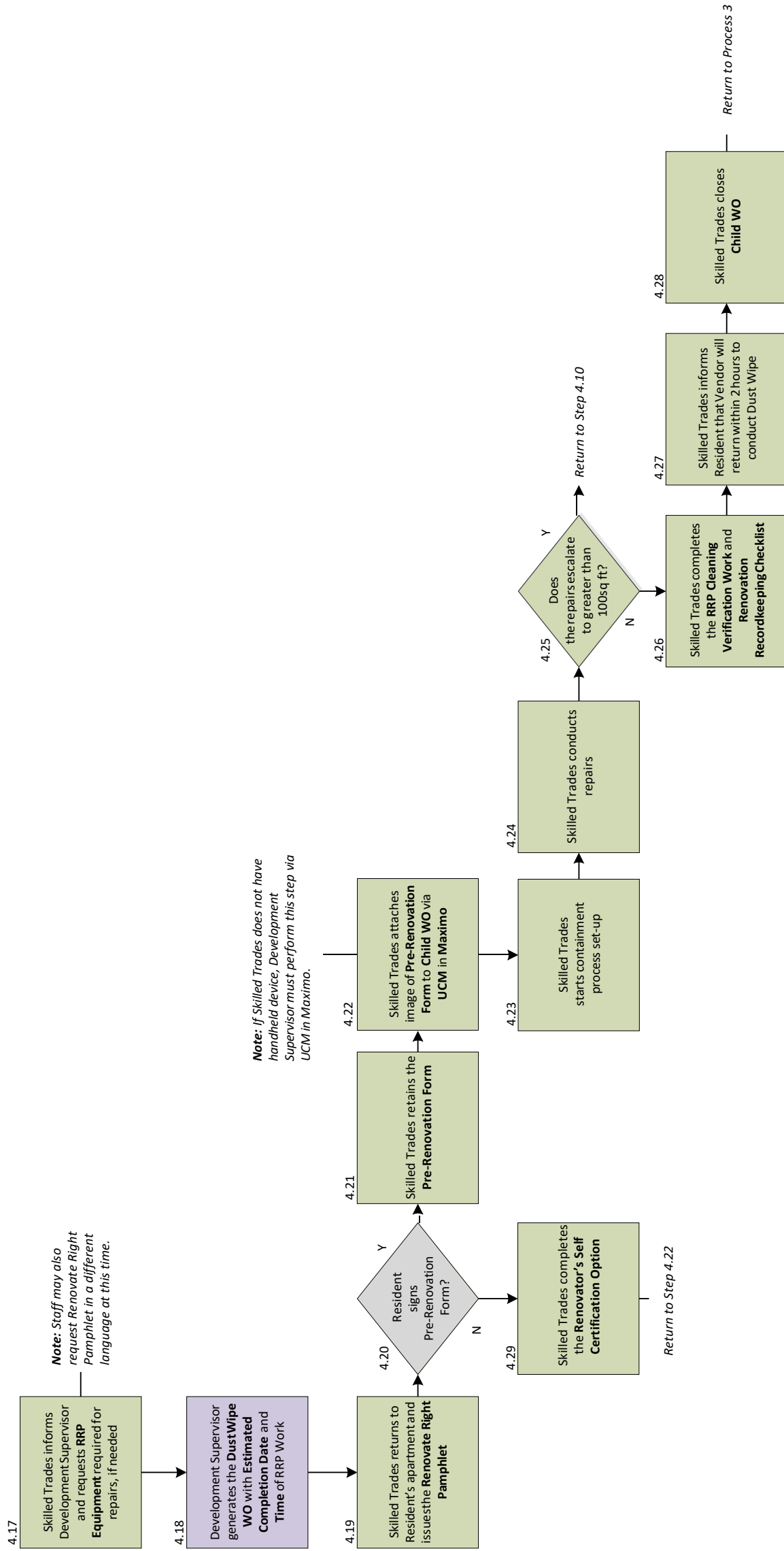

Process 5: Lead Abatement Worker Conducts Demolition

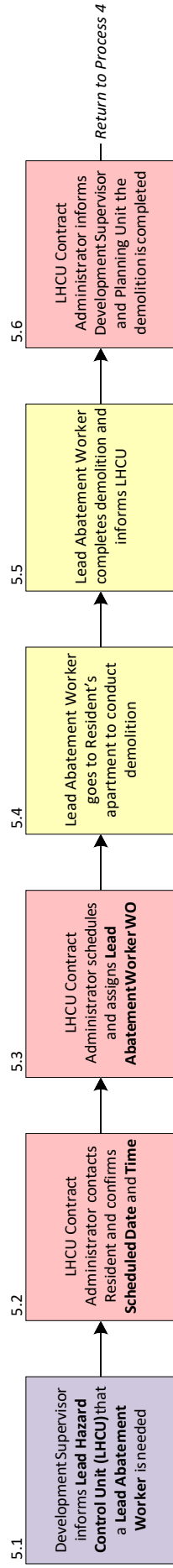

VIII. PROCEDURE

A. Assigning Certified Renovators

Only Certified Renovators can perform Renovation, Repair, and Painting (RRP) work that requires RRP certification.

1. A maintenance work order is created in Maximo.
 - a. Maximo displays one of the following messages on all corrective maintenance (CM) work orders – printed or handheld – where lead-safe practices may be required:
 - (1) “CAUTION: If paint is disturbed, work must be assigned to only RRP-certified staff/vendor and Lead Safe Work Practices must be followed.” (Orange message)
 - (2) “ACTION REQUIRED: RRP-certified staff/vendor must be used and Lead Safe Work Practices must be followed.” (Red message)
 - b. For the work to be performed, Maximo reflects in work order tracking the Failure Class/Problem Codes for which Certified Renovators are required. The list is available at this link:
<http://connect/private/Operations/PM/Interim%20Guidance1/Lead%20Safe>.
 - c. To locate the complete list of apartments that require RRP:
 - (1) Go to the Locations application in Maximo
 - (2) On the top left of the screen, expand the public queries icon
 - (3) Select ‘RRP required NYCHA Apartments’
 - d. Supervisors are not permitted to assign work that requires a Certified Renovator to employees who are not Certified Renovators. If an employee who is not a Certified Renovator is assigned to complete a work order that has the ACTION REQUIRED message noted above, the employee must tell their immediate supervisor that they are not certified to complete the work order.
 - e. In Assignment Manager and ESD Dispatching, the Labor List has a field to indicate which employees are Certified Renovators. The RRP certification information is imported from the Human Resources Database daily.
2. A maintenance worker verifies the work that needs to be performed.
3. If during verification, the maintenance worker disturbs more than two (2) square feet or more of presumed lead-based paint, then RRP procedure must be followed.

NOTE:	From this point forward, the NYCHA worker performing the RRP work is referred to as the employee.
--------------	---

4. Determination of RRP Work

- a. For all Maximo work orders where lead-safe practices may be required, the employee brings the equipment required to perform RRP work when they go to the work site. If additional supplies are needed, the employee contacts the supervisor to have it delivered to the location. See Section VIII.E., Employee Safety, and Section VIII.F., Supplies, below.
- b. When the employee goes to the work site, the employee determines if lead-based RRP work is required based on the following criteria.
 - (1) Work must be performed by a Certified Renovator if an interior surface that will be disturbed is two (2) square feet or more, or more than 10 percent of a small component per room or area.
 - (2) Work must be performed by a Certified Renovator if an exterior surface:
 - (a) Has more than 20 square feet of lead-based paint; or
 - (b) More than 10 percent of the total surface area of a component with a small surface area contains lead-based paint.
 - (3) Work must be performed by a Certified Renovator if the work includes window replacement, demolition, or activities involving prohibited practices (see Section VII.H.6., below).
- c. If the employee determines lead-based RRP work is required or if the estimated completion date or time changes, they make the indication on the work order in Maximo and immediately inform the development's property maintenance supervisor. The supervisor then contacts the contract administrator, who notifies the vendor of the change.
- d. If the employee determines RRP work on an interior surface will disturb more than 100 square feet of lead-based paint per room, or will include the removal of two or more painted windows, the work must be completed by lead abatement workers if:
 - (1) A child younger than six (6) years old lives in the apartment, as identified in Maximo; or
 - (2) The work is in a child-occupied facility.

For more information, see Section VIII.K., Work Disturbing More Than 100 Square Feet or Removing Two or More Painted Windows, below.

NOTE:	Employees should follow proper safety and dust control measures even when RRP work is determined to not be required, as described in the following sections: VIII.E., Employee Safety; VIII.G., Setting Up; VIII.H., Performing Work; and VIII.I., Cleaning Up.
--------------	---

- e. If the employee determines lead-based RRP work is not required, they follow the normal repair process.

5. Vendors

- a. Property maintenance supervisors ensure vendor employees:
 - (1) Are Certified Renovators.
 - (2) Have their RRP certificates on file at the development.
 - (3) Follow lead-safe work practices under federal and local law and regulations.
 - (4) Provide the required notifications.
- b. Developments provide vendors with the vendor notice explaining these obligations. See Appendix A, Lead Safe Practices Vendor Notice.

6. Exemption for Emergency Renovations

- a. The cleaning and cleaning verification requirements set forth in this policy are required for emergency renovations.
- b. For emergency renovations immediately necessary to safeguard against imminent danger to human life, health, or safety, or to protect property from further major damage, tenants must be protected from exposure to lead in dust and debris generated by such emergency actions to the extent practicable. Such emergencies include, but are not limited to, when property is damaged by:
 - (1) Natural disaster
 - (2) Fire
 - (3) Structural collapse
 - (4) Cascading water
 - (5) Lack of utilities

- c. The exemptions listed below only apply to repairs immediately necessary to respond to the emergency.
 - (1) Emergency renovations are exempt from requiring Certified Renovators to perform the work, to the extent necessary to respond to the emergency.
 - (2) The RRP requirements listed in the following sections are not required to be followed during an emergency renovation, to the extent necessary to respond to the emergency:
 - (a) Section VIII.B., Pre-Renovation Notice to Residents
 - (b) Section VIII.G., Setting Up
 - (c) Section VIII.H., Performing Work

NOTE:	RRP requirements apply to any work undertaken subsequent to or above and beyond such emergency actions.
--------------	---

B. Pre-Renovation Notice to Residents

- 1. The property manager and/or the property maintenance supervisor ensures sufficient copies of the EPA pamphlets, NYCHA Form 060.632, *The Lead-Safe Certified Guide to Renovate Right*, and NYCHA Form TR060632_02, *The Lead-Safe Certified Guide to Renovate Right Spanish Translation*, are available in the management office.
- 2. Work cannot begin in any location without all required documentation in this section being completed.

NOTE:	If the scope, locations, and/or scheduled work start and end dates change after NYCHA Form 060.632A, <i>Pre-Renovation Form</i> , and/or NYCHA Form 088.183, <i>Resident Renovation Notification Common Area</i> are provided, the employee provides an updated notice with the revised information. The updated notice must be provided before the work beyond what was described in the original notice begins.
--------------	---

3. Apartments

Resident notification for RRP work in apartments can be accomplished via hand delivery or via mail with a Certificate of Mailing.

a. Hand Delivery

- (1) The employee provides a hard copy of NYCHA Form 060.632, *The Lead-Safe Certified Guide to Renovate Right*, or NYCHA Form TR060632_02, *The Lead-Safe Certified Guide to Renovate Right Spanish Translation*, to the affected apartment(s).
- (2) The pamphlet must be provided no earlier than 60 days before, and no later than immediately before, beginning a renovation applicable to this Standard Procedure.
- (3) The employee uses NYCHA Form 060.632A, *Pre-Renovation Form*, to:
 - (a) Obtain the written acknowledgement of receipt from an adult representative in the apartment; or
 - (b) Document that the pamphlet was delivered but the employee was unable to obtain written acknowledgement.
- (4) The property maintenance supervisor ensures the completed form is uploaded to the Maximo work order, via either photo or scanning.

b. Mail with a Certificate of Mailing

If the pamphlet is sent via mail with a Certificate of Mailing, it must be sent no earlier than 60 days before, and no later than seven (7) days before beginning the renovation. See NYCHA Standard Procedure 005:11:1, *Mail Center Operations*, for more information.

4. Common Areas and Exteriors

A development notifies the residents of the affected apartments in a building no more than 60 days before, and no less than immediately before, beginning a renovation in a common area.

a. The information provided in the notice must include:

- (1) A description of the nature and location of the work
- (2) The scheduled work start and end dates
- (3) Information on how to obtain a copy of NYCHA Form 060.632, *The Lead-Safe Certified Guide to Renovate Right*, and NYCHA Form TR060632_02, *The Lead-Safe Certified Guide to Renovate Right Spanish Translation*.

b. The information may be provided by the following methods:

- (1) Posting copies of NYCHA Form 088.183, *Resident Renovation Notification Common Area*, where they are likely to be seen by the residents of all affected apartments; or

NOTE:	For recordkeeping purposes, if the employee has a NYCHA-issued handheld device, the employee takes a photo of the posted forms and uploads them to the Maximo work order. If the employee does not have a NYCHA-issued handheld device, the employee informs the property maintenance supervisor, who ensures a copy of the form is uploaded to the Maximo work order.
--------------	---

- (2) Hand delivery of NYCHA Form 060.632, *The Lead-Safe Certified Guide to Renovate Right*, or NYCHA Form TR060632_02, *The Lead-Safe Certified Guide to Renovate Right Spanish Translation*, to every affected apartment in the building; or
- (3) Mail NYCHA Form 060.632, *The Lead-Safe Certified Guide to Renovate Right*, or NYCHA Form TR060632_02, *The Lead-Safe Certified Guide to Renovate Right Spanish Translation*, with a Certificate of Mailing, to every affected apartment in the building
 - (a) If the pamphlet is sent via mail with a Certificate of Mailing, it must be sent no less than seven (7) days before beginning the renovation. See NYCHA Standard Procedure 005:11:1, *Mail Center Operations*, for more information.

5. Child-Occupied Facilities

If an apartment or common area is considered a child-occupied facility, the employee:

- a. Provides NYCHA Form 060.632A, *Pre-Renovation Form*, to a representative of the facility; and
- b. Posts NYCHA Form 088.183, *Resident Renovation Notification Common Area*, in the work area; or
- c. Provides a copy of the form to the parents or guardians of all children who use the facility.

C. Dust Wipe Work Orders

Any time RRP work is required, a dust wipe work order must be created. The dust wipe work order is created before RRP work begins to facilitate scheduling of the dust wipe vendor.

1. A dust wipe work order can be created by paper or handheld device.

a. Paper Work Order

The employee informs the property maintenance supervisor or assistant property maintenance supervisor of the need to create a dust wipe work order in Maximo for a vendor to perform a wipe inspection upon completion of the work.

b. Handheld Device Work Order

The employee selects the 'Yes' button on their handheld device. This automatically creates a dust wipe work order and sends an e-mail to the property maintenance supervisor and Lead Hazard Control Department contract administrator.

2. The property maintenance supervisor or assistant property maintenance supervisor:

a. Generates the work order with the following codes:

(1) Owner group: TSDECS

(2) Failure class: Lead

(3) Problem code: leadindustclearance

b. Enters the estimated date and time of completion of the work in the Target Start section.

NOTE:	If the estimated completion date or time changes, the development's property maintenance supervisor immediately contacts the contract administrator, who notifies the vendor of the change.
--------------	---

3. The Lead Hazard Control Department contract administrator schedules a dust wipe work order for a vendor based on the target start date entered on the parent work order.

a. The vendor is required to be on-site to perform a dust clearance examination in accordance with the terms of their contract.

D. Renovation, Repair, and Painting Work

1. Employees must have their certifications, including any refresher course certifications, with them on-site when they perform RRP work.

a. Employees must carry a physical copy of the certification with them; or

b. Must have an electronic copy of the certification on their mobile device.

2. The employee sets up containment of the work area. See Section VIII.G., Setting Up, below.
3. The employee performs the work. See Section VIII.H., Performing Work, below.
4. The employee cleans the work area. See Section VIII.I., Cleaning Up, below.
5. The employee begins the clearance process. See Section VIII.J., Clearance, below.

NOTE:	If a tenant is not home during any part of the work process, refer to the Tenant Not Home flow chart above in Section VII.B.
--------------	--

E. Employee Safety

1. Personal Protective Equipment (PPE)

- a. All employees performing work under this Standard Procedure are recommended to use the following:

- (1) Disposable coveralls, including hood and shoe covering
- (2) Gloves
- (3) Head covering
- (4) Respiratory protection (Disposable N-100, P-100, or R-100 respirators)
- (5) Safety goggles

2. Make It Safe

If an employee recognizes a hazard that could cause harm to themselves or co-workers, they must stop the hazardous task, or stop working in the hazardous condition. Please refer to NYCHA Standard Procedure 001:15:3, *Make It Safe Process*, for more information.

F. Supplies

1. The property manager and property maintenance supervisor ensure an adequate amount of supplies from the list below are maintained. It is recommended that each HEPA vacuum be packaged as a set by including all the items listed below and assigned to employees as needed.
 - a. HEPA vacuum and filters

- b. 6 mil polyethylene sheeting (for floors)
 - c. 2 mil polyethylene sheeting (for furniture and fixtures)
 - d. 6 mil polyethylene bags
 - e. Flip mops
 - f. Wet disposable soft wipes
 - g. 2 string mops
 - h. 2 buckets and wringer(s)
 - i. Lead-specific cleaning detergent
 - j. Water mister or spray bottle
 - k. Duct tape
 - l. Painters tape
 - m. Utility knife
 - n. Paper towels / rags
 - o. NYCHA Form 060.632, *The Lead-Safe Certified Guide to Renovate Right*
 - p. NYCHA Form 088.182, *Renovation, Repair, and Painting Safety Sign*
2. Employees can check with the property maintenance supervisor or assistant property maintenance supervisor for the location of the required supplies at the development.
- a. If all of the required supplies are not available, the employee changes the status of the work order to 'awaiting material,' and reschedules the work.
 - b. If the work is an emergency renovation and all of the required supplies are not available, the employee ascertains if the work can be completed with the materials that are present.

G. Setting Up

1. Signage

a. Outside the Work Area

- (1) Employees post NYCHA Form 088.182, *Renovation, Repair, and Painting Safety Sign*, before work begins.
- (2) The signs are posted at each entrance to a work area to define the work area, and/or at each main and secondary entrance to a building.
- (3) The signs must remain until cleaning verification is completed.
- (4) Translations of NYCHA Form 088.182, *Renovation, Repair, and Painting Safety Sign*, are kept in the Property Management Office. They are provided to any resident who requests one.
 - (a) Spanish: NYCHA Form TR088182_02
 - (b) Russian: NYCHA Form TR088182_03
 - (c) Chinese: NYCHA Form TR088182_04

b. Inside the Work Area

The employees post NYCHA Form 088.182, *Renovation, Repair, and Painting Safety Sign*, inside each contained work area.

2. Site preparation

Before beginning the RRP work, the employees prepare the work area using the following actions.

a. Apartments, Common Areas, and Child-Occupied Facilities

- (1) In apartments, discuss the following with the resident:
 - (a) Extent of containment needed
 - (b) How the containment area will be prepared
 - (c) Advise residents not to enter the containment area until after clean-up
 - (d) Direct residents not to allow children to enter any area in which plastic sheeting is being used or stored due to the risk of suffocation

- (2) Secure the apartment and/or work area against unauthorized entry.
- (3) Move all objects out of the room, if possible.
- (4) Cover all items which were not moved from the work area with one layer of disposable polyethylene sheeting. The sheeting must be taped together with duct tape, and taped to the floors or bottom of the walls or baseboards, to form a continuous barrier to the penetration of dust.
- (5) Cover the floor of the work area with one layer of six-mil disposable polyethylene sheeting, and tape the sheeting down to prevent movement. The floor sheeting must extend six (6) feet in all directions from the work area where practical, unless vertical containment is installed. Use two layers of sheeting to cover wall-to-wall carpeting, overlapping the seams by at least six (6) inches.
 - (a) If vertical containment is used, the floor covering may stop at the vertical barrier, if it is impermeable, extends from the floor to the ceiling, and is tightly sealed at all floors, ceiling, and walls.
- (6) Cover the work area entrance or vertical containment doorway with one layer of sheeting. Tape the sheeting to the top of the door frame or vertical containment high point and weigh down the bottom to create a seal. Create a door flap on the sheeting that allows access into the work area.
- (7) Close and cover all forced air systems (HVAC) in the work area with one layer of disposable polyethylene sheeting, including bathroom vents, common area vents, exhaust vents, and hall vents.
- (8) Close windows, and where applicable, cover the windows with one layer of sheeting to prevent dust and debris from settling on windowsills.
- (9) In kitchens and bathrooms, cover counter tops, cabinets, sink base cabinets, and all other horizontal surfaces with sheeting, to ensure that all doors and drawers are sealed.
- (10) In kitchens:
 - (a) Cover the stove with sheeting and seal. Ensure that the stove is off and cool to the touch before covering.
 - (b) Cover and seal the refrigerator with sheeting. Prior to covering, cut slits in the sheeting to allow for ventilation.

b. Exteriors

(1) Work Area Perimeter

- (a) Create a 20-foot perimeter around the work area if space allows.
- (b) Use signs with orange cones, saw horses, warning tape, and/or ropes to mark off the work area.
- (c) Extend the work area farther if needed; for example, when paint on the second story of a building is disturbed.
- (d) Cover nearby vegetable gardens and children's play areas.

(2) Doors and Windows

- (a) Close all doors and windows on the same floor within 20 feet of the work area, and all windows on all floors below that are the same horizontal distance from the renovation.
- (b) If the doors and windows of apartments are less than 20 feet from the work area, consider asking the residents of those affected apartments to close the affected windows and doors. If this is not possible, erect a vertical containment wall at the property line.

(c) Doors Used as Entrances to the Work Area

Cover any doors used as entrances to the work area or vertical containment doorway with one layer of sheeting. Tape the sheeting to the top of the door frame or vertical containment high point and weigh down the bottom to create a seal. Create a door flap on the sheeting that allows access into the work area.

(3) Ground

- (a) Cover the ground with plastic sheeting or other impermeable material
- (b) If there is enough space, extend the sheeting a minimum of 10 feet beyond the perimeter of surfaces being worked on or to a sufficient distance to contain dust, whichever is greater, unless the property line prevents 10 feet of such ground cover in which case the employee must erect a vertical containment.
 - i. If a vertical containment is erected closer to the work area than the minimum ground containment distance, the ground containment may stop at the edge of the vertical containment.

(4) Vertical Containment

Vertical containment must be erected when work is done within 10 feet of the property line.

(5) Other Items

- (a) Cover any items that cannot be relocated out of the work area.
- (b) Tape the protective sheeting to the wall of the building or use a 2x4 wrapped in protective sheeting to hold the material next to the wall. Use heavy objects to weigh the other edges of the protective sheeting to the ground to secure.
- (c) When using ladders on plastic sheeting, place a sturdy piece of plywood on the plastic and then set the ladder on the plywood to prevent the ladder from puncturing the plastic and to provide a stable surface for the ladder. If plywood is used, take special care to secure it to the ground so that it does not move.

H. Performing Work

While performing the work, employees observe the following guidelines:

1. Using the spray water bottle, spray the surfaces that will be disturbed to limit the creation and dispersal of dust. Periodically rewet the area while working.
2. For painted surfaces, if a component is to be removed from an underlying surface, score the perimeter/edge of the component with a utility knife to minimize the quantity of painted surface that is impacted.
3. If power tools are used that impact lead-based paint, only those equipped with a vacuum attachment connected to a HEPA vacuum are allowed to be used.
4. Observe safety precautions in contained work areas:
 - a. Do not eat or drink in the work area.
 - b. Keep polyethylene sheeting away from open flames, e.g. stoves and blowtorches.
 - c. Exercise caution when spraying in the vicinity of electrical outlets.
 - d. Prevent children and pets from entering the work area.
5. Immediately repair torn sheeting using duct tape for minor tears. Total sheet replacement may be necessary for major tears.

6. The following work practices are prohibited:
 - a. Open flame burning or torching of painted surfaces.
 - b. Use of machines that remove paint or other surface coatings through high-speed operation, unless they have shrouds or containment systems and are equipped with a HEPA vacuum attachment.
 - c. Operating a heat gun on painted surfaces above 1100 degrees Fahrenheit or charring the paint.
 - d. Paint stripping using a volatile stripper in poorly ventilated space.
 - e. Dry sanding or scraping, except within one (1) foot of electrical fixtures (e.g. switches, outlets, light fixtures, breaker boxes).

I. Cleaning Up

1. Work That Exceeds Eight Hours

If work is not completed at the end of an eight-hour shift, at the end of work on each day:

- a. The work area must be contained to prevent the release of leaded dust and debris into other areas and other safety, health, or environmental hazards; and
- b. The work area must be cleaned within at least 10 feet of the containment area to remove any visible dust or debris, and so other areas of the apartment or common area are accessible.

NOTE:	If after the above containment and cleaning is performed tenants still do not have access to sleeping areas, bathrooms, and kitchens, employees must refer to NYCHA Standard Procedure 002:06:01, <i>Planned Relocation</i> .
--------------	---

2. After work is completed, employees clean up in the following sequence:

- a. Worksite
- b. Vacuuming
- c. All horizontal surfaces except floors
- d. Floors, including two (2) feet beyond the containment area in all directions from the work area

3. Worksite

- a. Remove all containment that interferes with cleaning the work area. Any containment that does not impact cleanup must remain in place until after clearance.

(1) Instruct the resident to not enter the work area until containment is removed.

- b. Pick up all debris too large for a vacuum cleaner and place it in six-mil polyethylene bags and/or a covered cart. Avoid puncturing bags with pointed or jagged pieces of debris.

- c. With a spray bottle, moisten the polyethylene sheeting and fold it inward.

- d. Place the plastic sheeting into six-mil polyethylene bags and/or a covered cart.

(1) Close all bags with an airtight gooseneck seal:

(a) Twist the bag

(a) Fold it over on itself

(b) Wrap it with duct tape

(c) Dispose of it with regular household waste

- e. Clean all tools.

4. Vacuuming

- a. Vacuum remaining dust and debris in the work area at a moderate speed. A HEPA vacuum is required. Never dry sweep dust or debris.

- b. First, vacuum every inch of all horizontal surfaces except floors, such as window sills, window troughs, countertops, light fixtures, cabinets, cabinet door edges, and any other horizontal surface where dust can accumulate.

- c. Then, vacuum floors starting at the far end of the room, working toward the entrance.

- d. If work was performed in kitchen, vacuum the condenser and fan area underneath the refrigerator.

- e. Avoid stepping on already vacuumed floors when moving to a new section.

5. Cleaning of Horizontal Surfaces Except Floors

- a. Use the disposable soft wipe method (preferred) or the two-bucket method.

- b. Wipe all horizontal surfaces except floors, such as window sills, window troughs, countertops, light fixtures, cabinets, cabinet door edges, and any other horizontal surface where dust can accumulate.
- c. Clean all horizontal surfaces except floors until wipes are clear of dust.

6. Cleaning of Floors

- a. Use the disposable soft wipe method (preferred) or the two-bucket method.
 - (1) If using the two-bucket method, before mopping, dump the water from the clean rinse bucket used for the horizontal surfaces and refill it with clean cold water.
- b. Mop all floors starting at the far end of the room, working towards the entrance.
- c. Avoid stepping on already mopped floors when moving to a new section.
- d. If using the two-bucket method, discard dirty water in the toilet.
 - (1) For work in common areas, discard dirty water in empty five-gallon pails, put lids on them, and transport them to the nearest toilet to discard.
- e. Clean all floors until wipes are clear of dust.

7. Employees close the work order after completing cleaning activities.

J. Clearance

1. Apartments, Common Areas, and Child-Occupied Facilities

- a. The employee who performed the RRP work fills out NYCHA Form 088.184, *Staff Renovation Recordkeeping Checklist*.
 - (1) If a vendor performed the RRP work, the vendor fills out NYCHA Form 088.181, *Vendor Renovation Recordkeeping Checklist*.
- b. The dust wipe vendor performs a dust clearance examination within two (2) hours of completion of the work order.

NOTE:	If a vendor performed the RRP work, a separate vendor must perform the dust clearance examination.
--------------	--

- c. The Lead Hazard Control Department contract administrator closes the dust wipe vendor work order.

- d. Dust wipe results may be available within eight (8) hours of completion of a dust clearance examination dependent on the date and time of the examination.
- e. If the dust wipe vendor does not clear the work site, or the tenant is not home, the Lead Hazard Control Department contract administrator generates a new clearance work order for staff to re-clean the work area, as outlined above in Section VIII.C., Dust Wipe Work Order. Employees then must repeat the tasks outlined above in Section VIII.I., Cleaning Up.

2. Exteriors

For exterior work, HUD requires only a visual assessment of the work area to pass clearance. No dust or soil testing is required.

a. Visual inspection

- (1) A vendor conducts a visual inspection after cleaning is completed.
- (2) If dust, debris, or residue is present on surfaces in and below the work area, including window sills and the ground, these conditions must be eliminated by re-cleaning.
- (3) After re-cleaning, the vendor conducts another visual inspection.
- (4) After all areas pass inspection, warning signs may be removed.

K. Work Disturbing More Than 100 Square Feet or Removing Two or More Painted Windows

For more information, refer to the Lead Abatement Worker Conducts Demolition flow chart above in Section VII.E.

1. Identifying Work Area

- a. When the employee verifies the work that needs to be performed as outlined above in Section VIII.A.4., they determine the total square footage of the painted area that will be disturbed in each room, and whether any work areas have two or more painted windows that will be removed.
- b. If the total area being disturbed in any room is more than 100 square feet of lead-based paint, or involves the removal of two or more painted windows, the employee confirms if a child younger than six (6) years old lives in the apartment, as identified in Maximo, or if the room is in a child-occupied facility.
- c. If a child younger than six (6) years old lives in the apartment, as identified in Maximo, or the room is in a child-occupied facility, the employee does not proceed with the work in that room.

- d. The employee informs the property maintenance supervisor of the need for a lead abatement worker.
- e. The property maintenance supervisor creates a work order for lead abatement worker demolition and contacts the Lead Hazard Control Department.

NOTE:	If the work order includes work in additional rooms that have less than 100 square feet of lead-based paint being disturbed, and/or areas that do not involve removing two or more painted windows, employees proceed with the RRP work in those rooms and areas.
--------------	---

- 2. **After RRP work begins, if an employee determines the size of the area will exceed the original scope of work and now will exceed 100 square feet of lead-based paint being disturbed, or will involve the removal of two or more painted windows, the employee immediately stops work in that room and refers to Sections VIII.K.1.b.-VIII.K.1.d. directly above.**
- 3. The property maintenance supervisor coordinates with the relevant trade(s) for restoration work after the lead abatement workers complete their work.
- 4. Notice of Commencement
 - a. The Lead Hazard Control Department environmental health and safety coordinator files a notice of commencement of work with the New York City Department of Mental Health and Hygiene (DOHMH) not less than 10 days prior to beginning the work. The form is found at: <https://www1.nyc.gov/assets/doh/downloads/pdf/lead/lead-notificationform.pdf>.
 - b. If work is required to begin in less than 10 days, the notice of commencement must be filed as soon as practicable but prior to beginning the work.
 - c. The notice must be filled out completely and submitted according to the instructions on the form.
 - (1) Fill in the 'Building Owner Information' section with the following: New York City Housing Authority, 250 Broadway, New York, NY, 10007, 212-306-3000.
 - d. A copy of the notice of commencement of work must be posted between 24 and 96 hours before work begins. It must be posted at the entrance to the building and the entrance of the specific apartment where work will take place.
 - e. Any changes to the information included in the notice of commencement of work must be filed with DOHMH prior to starting work, or if work already started, within 24 hours of any such change.

IX. OUTPUTS, REPORTS, AND RECORDKEEPING

A. Outputs

1. Completing identified tasks within required timelines and compliance standards
2. Providing all required notifications to residents, including posting all required notices
3. Retaining all required documents in identified locations

B. Reports

Reports related to this Standard Procedure are maintained in the NYCHA Data Warehouse on NYCHA Connect. Reports are generated upon request or as needed.

C. Recordkeeping

1. Developments retain hard copies of all forms associated with this Standard Procedure for no less than 10 years from the completion date of work.
 - a. The vendor provides hard copies of NYCHA Form 088.181, *Vendor Renovation Recordkeeping Checklist*, to the property maintenance supervisor.
2. Digital forms associated with this Standard Procedure are retained in Maximo.

X. TRAINING REQUIREMENTS

A. The Human Resources Department Learning and Development-Registration Unit:

1. Serves as a liaison for obtaining training.
2. Tracks training certifications.
3. Schedules new employees for training.

B. All new employees who this Standard Procedure applies to are required to:

1. Attend Renovation, Repair, and Painting training.
2. Receive their certification by achieving a successful result on the exam administered at the end of the training. The training certification is valid for five (5) years.

XI. PERFORMANCE METRICS

- A. Pass/fail rate of dust wipes
- B. Average number of days to close a dust wipe work order
- C. Percentage of dust wipe work orders closed within established timelines
- D. Percentage of work orders delayed caused by a lack of RRP materials
- E. Percentage of RRP compliance observations in complete adherence to the RRP rule

XII. NON-COMPLIANCE

- A. NYCHA staff performing or overseeing RRP work are required to comply with this Standard Procedure and any federal, state, or city regulations pertaining to the work described in it.
- B. Departments are required to take corrective action to bring NYCHA into compliance.

XIII. FORMS

The following forms and signs are located on the Forms and Reference Library.

- A. NYCHA Form 060.632, *The Lead-Safe Certified Guide to Renovate Right*
- B. NYCHA Form TR060632_02, *The Lead-Safe Certified Guide to Renovate Right Spanish Translation*
- C. NYCHA Form 060.632A, *Pre-Renovation Form*
- D. NYCHA Form 088.181, *Vendor Renovation Recordkeeping Checklist*
- E. NYCHA Form 088.182, *Renovation, Repair, and Painting Safety Sign*
- F. NYCHA Form TR088.182_02, *Renovation, Repair, and Painting Safety Sign, Spanish Translation*
- G. NYCHA Form TR088.182_03, *Renovation, Repair, and Painting Safety Sign, Russian Translation*
- H. NYCHA Form TR088.182_04, *Renovation, Repair, and Painting Safety Sign, Chinese translation*
- I. NYCHA Form 088.183, *Resident Renovation Notification Common Area*
- J. NYCHA Form 088.184, *Staff Renovation Recordkeeping Checklist*

XIV. REVIEW/REVISION HISTORY PAGE

LEAD SAFETY FOR RENOVATION, REPAIR, AND PAINTING

040:18:2

Review/ Revision	Review/ Revision Date	Sections Amended
1.		
2.		
3.		
4.		
5.		
6.		
7.		
8.		
9.		

XV. APPENDICES

A. Lead Safe Practices Vendor Notice

Appendix appears on following page.



Lead Safe Practices Vendor Notice

Dear Vendor:

Please be advised that your firm and your staff are required to comply with Lead Safe Work practice requirements as part of general maintenance and repair in accordance with NYC Local Law 1 and/or HUD requirements and must be RRP certified.

If vendor employees enter the apartment and determine that the amount of painted surface being disturbed is greater than 2 square feet or 10% of the component, vendor employees are required to follow Lead Safe Practices and:

- Provide a paper copy of the [EPA Renovate Right Brochure](#) to the resident before commencing work.
- Collect the completed Occupant Confirmation form (found in the brochure) from the resident.
- Indicate the work order # on the Occupant Confirmation form.
- Immediately inform the Property Maintenance Supervisor or Assistant Property Maintenance Supervisor of the need for clearance dust wipes.
- Return the Occupant Confirmation form to the Property Maintenance Supervisor.

Please be advised that your staff can obtain copies of the Renovate Right Brochure from the Development Office.

B. RRP Supplemental Workflow

Appendix begins on following page.

Row #	Step #	Action Description	YES	Go to Process	NO	Go to Process
PROCESS 1: Maintenance Worker Verifies Complaint						
1	1.1	Maintenance Worker goes to Resident's apartment on Scheduled Date and Time				
2	1.2	Is Resident Home?	YES	Go to Step 1.3	NO	Go to Process 3
3	1.3	Maintenance Worker Verifies Complaint				
4	1.4	Can Maintenance Worker complete repairs?	YES		NO	Go to Step 1.9 & 1.10
5	1.5	Is 2 sq. ft. or more of RRP Work Required?	YES	Go to Step 1.7	NO	Go to Step 1.11
6	1.6	Is RRP Equipment available?	YES		NO	Go to Step 1.12 & 1.13
7	1.7	Maintenance Worker informs Development Supervisor and requests any additional RRP Equipment required for repairs to be brought to apartment, if needed. (HEPA Vac, respirator, additional sheathing, duct and painters tape etc.)				
8	1.8	Development Supervisor generates the Dust Wipe WO with Estimated Completion Date and Time of RRP Work				
9	1.9	Maintenance Worker generates Child WO for Skilled Trades Needed				
11	1.10	Planning Unit schedules Skilled Trades Child WO		Go to Process 4		
12	1.11	Maintenance Worker follows normal repair process and closes Parent WO. Note: Maintenance staff must notify Development supervisor of any changes in estimated completion times as soon as they become aware of change				
13	1.12	Development Supervisor reschedules Maintenance WO when RRP materials are obtained		End		
14	1.13	Was Equipment obtained?				
15	1.14	Maintenance Worker issues the Renovate Right Pamphlet to Resident Note: Staff may request different language pamphlet.	YES	Go to Step 1.15	NO	Return to Step 1.13
16	1.15	Resident signs Pre-Renovation Form?				
17	1.16	Maintenance Worker retains the Pre-Renovation Form	YES	Go to Step 1.17	NO	Go to Step 1.22
18	1.17	Maintenance Worker attaches Pre-Renovation Form to Parent WO via Unified Change Management (UCM) in Maximo Note: If Maintenance Worker does not have handheld device, Development Supervisor must perform this step.				
19	1.18	Maintenance Worker starts containment process set-up and completes repairs				
20	1.19	Maintenance Worker completes the RRP Cleaning Verification Work and Renovation Recordkeeping Checklist				
21	1.20	Maintenance Worker informs Resident that Vendor will return within 2 hours to conduct Dust Wipe				
22	1.21	Maintenance Worker closes Parent WO		Go to Process 3		
23	1.22	Maintenance Worker completes the Renovator's Self Certification Option		Return to Step 1.17		

Row #	Step #	Action Description	YES	Go to Process	NO	Go to Process
PROCESS 2: Tenant Not Home						
29	2.1	Is this a Maintenance WO?	YES	Go to Step 2.2	NO	Go to Step 2.9
30	2.2	Maintenance Worker contacts Resident via handheld				
31	2.3	Was Contact successful?	YES	Return to Step 1.3	NO	Go to Step 2.4
32	2.4	Was appointment initiated by resident?	YES	Go to Step 2.5	NO	Go to Step 2.8
33	2.5	Maintenance Worker marks WO Tenant Not At Home and places a Notice of Visit by NYCHA Staff (NYCHA Form# 040.534A) under the door				
34	2.6	Maintenance Worker informs Development Supervisor the Resident was not home				
35	2.7	Development Supervisor contacts Resident and reschedules Maintenance WO, if applicable				
36	2.8	Maintenance Worker marks WO Tenant Not At Home and places a Notice of Visit by NYCHA Staff – Apartment Inspection (NYCHA Form# 040.534) under the door				
37	2.9	Is this a Skilled Trades WO?	YES	Go to Step 2.10	NO	End of Process
38	2.10	Skilled Trades Worker contacts Resident via handheld				
39	2.11	Was Contact successful?	YES	Return to Step 4.3	NO	Go to Step 2.12
40	2.12	Was appointment initiated by resident?	YES	Go to Step 2.13	NO	Go to Step 2.16
41	2.13	Skilled Trades Worker marks WO Tenant Not At Home and places a Notice of Visit by NYCHA Staff (NYCHA Form# 040.534A) under the door				
42	2.14	Skilled Trades Worker informs Development Supervisor the Resident was not home				
43	2.15	Development Supervisor contacts Resident and reschedules Skilled Trades Child WO, if applicable				
44	2.16	Skilled Trades Worker marks WO Tenant Not At Home and places a Notice of Visit by NYCHA Staff – Apartment Inspection (NYCHA Form# 040.534) under the door		Return to Step 2.14		

Row #	Step #	Action Description	YES	Go to Process	NO	Go to Process
PROCESS 3: Vendor Conducts Dust Clearance Examination						
51	3.1	Lead Hazard Control Unit (LHCU) Contract Administrator schedules Dust Wipe WO for Vendor				
52	3.2	Vendor goes to Resident's apartment on Scheduled Date and Time				
53	3.3	Is Resident home?	YES	Go to Step 3.4	NO	Go to Step 3.13
54	3.4	Vendor completes Visual Assessment & Dust Clearance Examination (Dust Wipe)				
55	3.5	LHCU Contract Administrator attaches Dust Wipe Report to the Dust Wipe WO in Maximo via UCM				
56	3.6	LHCU Contract Administrator completes and closes the Dust Wipe WO				
57	3.7	Dust Wipe Passed Note: Dust Clearance results may be available within 8 hours dependent on date and time of collection.	YES	End of Process	NO	Go to Step 3.8
58	3.8	Maximo auto-generates Cleaning Verification WO for Maintenance Worker				
59	3.9	Development Supervisor reschedules the Cleaning Verification WO with Estimated Completion Date and Time				
60	3.10	Maximo auto-generates Dust Wipe WO				
61	3.11	LHCU Contract Administrator re-schedules Dust Wipe WO and enters Target Start Date for Vendor				
62	3.12	Maintenance Worker completes RRP Cleaning Verification Work and Renovation Recordkeeping Checklist		Return to Step 3.12		
63	3.13	Vendor informs Development Supervisor Resident is not home				
64	3.14	Development Supervisor contacts Resident				
65	3.15	Was contact successful?				
66	3.16	Is Resident home?	YES	Go to Step 3.17	NO	Go to Step 3.18
67	3.17	Development Supervisor informs Vendor Resident was home and Vendor returns to apartment		Return to Step 3.4		
68	3.18	Development Supervisor informs LHCU Contract Administrator				
69	3.19	Development Supervisor reschedules the Cleaning Verification WO with Estimated Completion Date and Time		Return to Step 3.12		
70	3.20	LHCU Contract Administrator re-schedules Dust Wipe WO for Vendor		Return to Step 4.2		

Row #	Step #	Action Description	YES	Go to Process	NO	Go to Process
PROCESS 4: Skilled Trades Verifies Complaint						
76	4.1	Skilled Trades goes to Resident's apartment on Scheduled Date and Time				
77	4.2	Is Resident Home?	YES	Go to Step 4.3	NO	Return to Process 3
78	4.3	Skilled Trades assesses repairs				
79	4.4	Can Skilled Trades Complete repairs?	YES		NO	Go to Step 4.11 & 4.12
80	4.5	Is 2 sq. ft. or more of RRP Work Required?	YES		NO	Go to Step 4.13
81	4.6	Is amount of RRP square footage greater than 100sq. ft?	YES		NO	Go to Step 4.17
82	4.7	Does the WO indicate a child under 6 resides in apt?	YES		NO	Go to Step 4.14
83	4.8	Skilled Trades informs the Resident a Lead Abatement Worker is required to perform demolition and requests a Date and Time from Resident				
84	4.9	Skilled Trades sequences Child WO to the Lead Abatement Worker				
85	4.10	Skilled Trades informs Development Supervisor a Lead Abatement Worker is required to conduct demolition				
86	4.11	Skilled Trades generates Child WO for Skilled Trades Needed				
87	4.12	Planning Unit schedules Skilled Trades Child WO		Return to Step 4.1		
88	4.13	Skilled Trades follows normal repairs and closes Child WO. Note: Skilled Trades staff must notify Development supervisor of any changes in estimated completion times as soon as they become aware of change				
89	4.14	Is RRP Equipment available?	YES	Go to Step 4.17	NO	Go to Step 4.15
90	4.15	Planning Unit reschedules Skilled Trades Child WO when RRP materials are obtained				
91	4.16	Was Equipment obtained?	YES	Return to Step 4.18	NO	Return to Step 4.18
92	4.17	Skilled Trades informs Development Supervisor and requests RRP Equipment required for repairs, if needed				
93	4.18	Development Supervisor generates the Dust Wipe WO with Estimated Completion Date and Time of RRP Work				
94	4.19	Skilled Trades returns to Resident's apartment and issues the Renovate Right Pamphlet Note: Staff may request different language pamphlet.				
95	4.20	Resident signs Pre-Renovation Form?				
96	4.21	Skilled Trades retains the Pre-Renovation Form				
97	4.22	Skilled Trades attaches photo of Pre-Renovation Form to Child WO via UCM in Hand Held Device Note: If Skilled Trades does not have handheld device, Development Supervisor must perform this step via UCM in Maximo.				
98	4.23	Skilled Trades starts containment process set-up				
99	4.24	Skilled Trades conducts repairs				
100	4.25	Does the repairs escalate to greater than 100sq ft?	YES	Return to Step 4.10	NO	Go to Step 4.26
101	4.26	Skilled Trades completes the RRP Cleaning Verification Work and Renovation Recordkeeping Checklist				
102	4.27	Skilled Trades informs Resident that Vendor will return within 2 hours to conduct Dust Wipe				
103	4.28	Skilled Trades closes		Return to Process 3		

Row #	Step #	Action Description	YES	Go to Process	NO	Go to Process
PROCESS 5: Lead Abatement Worker Conducts Demolition						
105	5.1	Development Supervisor informs Lead Hazard Control Unit (LHCU) that a Lead Abatement Worker is needed				
106	5.2	LHCU Contract Administrator contacts Resident and confirms Scheduled Date and Time				
107	5.3	LHCU Contract Administrator schedules and assigns Lead Abatement Worker WO				
108	5.4	Lead Abatement Worker goes to Resident's apartment to conduct demolition				
109	5.5	Lead Abatement Worker completes demolition and informs LHCU				
110	5.6	LHCU Contract Administrator informs Development Supervisor and Planning Unit the demolition is completed		Return to Process 4		